

Technical Report No. 65

SACLANT ASW  
RESEARCH CENTRE

A COMPACT BUOY SYSTEM FOR SHIP-USE IN THE MEASUREMENT  
OF OCEAN MICRO-STRUCTURES OVER A MONTHLY PERIOD

by

R. FRASSETTO

1 OCTOBER 1966

NATO

VIALE SAN BARTOLOMEO, 92  
LA SPEZIA, ITALY

This document is released to a NATO Government at the direction of the SACLANTCEN subject to the following conditions:

1. The recipient NATO Government agrees to use its best endeavours to ensure that the information herein disclosed, whether or not it bears a security classification, is not dealt with in any manner (a) contrary to the intent of the provisions of the Charter of the Centre, or (b) prejudicial to the rights of the owner thereof to obtain patent, copyright, or other like statutory protection therefor.

2. If the technical information was originally released to the Centre by a NATO Government subject to restrictions clearly marked on this document the recipient NATO Government agrees to use its best endeavours to abide by the terms of the restrictions so imposed by the releasing Government.

NATO UNCLASSIFIED

TECHNICAL REPORT 65


SACLANT ASW RESEARCH CENTRE  
Viale San Bartolomeo 92  
La Spezia, Italy

A COMPACT BUOY SYSTEM FOR SHIP-USE IN THE MEASUREMENT  
OF OCEAN MICRO-STRUCTURES OVER A MONTHLY PERIOD

By

R. Frassetto

APPROVED FOR DISTRIBUTION



HENRIK NØDTVEDT

Director

NATO UNCLASSIFIED

Manuscript Completed:

26 May 1966

## TABLE OF CONTENTS

	<u>Page</u>
ABSTRACT	1
INTRODUCTION	3
1. GENERAL DESIGN	5
2. THE INTEGRATED UNITS OF ARRAY 1	8
2.1 Basic Circuit of the Transducers	8
2.2 The Probes	10
2.3 The Programmer	11
2.4 The Recorder	13
2.5 Power Supply	17
2.6 The Conductive Mooring Cable, its Swivels and Joints	17
3. THE INDEPENDENT UNITS OF ARRAY 2	20
4. THE CALIBRATION OF PROBES	21
4.1 Thermometer Probes	21
4.2 Current Probes	21
4.3 General	22
5. DATA CONVERSION	23
5.1 Data from Array 1	23
5.2 Data from the individually self-recording instruments of Array 2	25
6. THE MOORING ASSEMBLY	26
6.1 General	26
6.2 The Mooring Line	26
6.3 The Buoys	28
6.4 The Anchoring System and its Releasers	31
7. MECHANICS: HANDLING AT SEA	32
7.1 Storage	32
7.2 Launching	32
7.3 Recovery	33

## TABLE OF CONTENTS (Cont'd)

	<u>Page</u>
8. RESULTS	35
8.1 Field History of the Buoys	35
CONCLUSION AND RECOMMENDATIONS	41
FIGURES	43
APPENDIX 1 - SUMMARY OF CERTAIN FUNDAMENTALS	65
APPENDIX 2 - THE DETAILED CIRCUIT DIAGRAM OF THE PROGRAMMER	68
APPENDIX 3 - PRECISION MINIATURE TIMER FOR THE PROGRAMMER	69
APPENDIX 4 - SPECIFICATIONS OF THE ELECTRICALLY INSULATED WIRE ROPE PRESENTLY USED	70
APPENDIX 5 - MOORING LINE MOTION	71
APPENDIX 6 - CABLE VIBRATIONS AND TORQUE	74
REFERENCES	82
BIBLIOGRAPHY	83

A COMPACT BUOY SYSTEM FOR SHIP-USE IN THE MEASUREMENT  
OF OCEAN MICRO-STRUCTURES OVER A MONTHLY PERIOD

By

R. Frassetto

ABSTRACT

The oceanographic buoy described is for ship use. It allows a single ship to make synoptic studies of a limited body of water using a number of buoys.

The purpose was to create an economic, simple, dependable sea unit, which allows for accidental losses, matched to a more sophisticated data processing system that represents a durable investment.

The sea unit is of small size, light weight in air and water, and easy to launch and retrieve. The low drag of buoys and cable permits their use in areas of strong currents.

The sensing capabilities of the first-generation system are temperature, current speed and direction, and depth. The data storage capacity is of 16 000 cycles or about 400 000 individual data. Recording is intermittent, with maximum sampling rate of 30 seconds. The system is engineered for one month operation, which is considered a reasonable cruising time for a ship in a limited area of the ocean.

It is a subsurface system that can also be used, if needed, with a small RF data transmitter on the surface. The system permits a simple link between field observations and a digital computer. Calibration and mooring motion corrections can be made automatically in the data processing phase.

The system has been used since 1963 in the Strait of Sicily and on three occasions in the Strait of Gibraltar, where unusual oceanographic conditions are found and where the buoys were exposed to strong dynamic forces.

Field experience with the first generations of the system showed that substantial improvements could be made, particularly towards obtaining the utmost simplicity, dependability, and sea-worthiness. These qualities will improve along with the progress of technology and the availability of cheaper and better quality miniaturized components.



## INTRODUCTION

Buoy technique is acquiring an ever-increasing importance in oceanographic research, but is far from perfected. During the last decade various agencies have independently developed buoy systems for the collection of oceanographic and meteorological data, but the work is still very much in the exploratory stage.

The majority of these buoys, however, have been developed for long-term recording and long-range telemetering of a variety of measurements made at individual, widely-spaced positions. They have therefore been designed to work unattended for several months or years, and, in consequence, are large, complex, difficult to handle, and represent a substantial investment per unit. The unified systems developed for the computer analysis of the time-varying data obtained from these buoys have also proved expensive. Thus most oceanographic institutes have been prohibited, on economic bases alone, from considering studies that make extensive use of buoys for data collection.

The moored buoy system described in this report follows a different philosophy. It is intended to be a convenient tool by which a single ship can make synoptic studies of limited bodies of water, especially in the study of the microstructures of the ocean's upper layers.

A reasonable recording duration for most such studies is 15 to 30 days, which is also a convenient time for a research vessel to remain at sea; the buoy has therefore been made to operate for a maximum of 30 days. It was designed to reach the utmost in compactness, simplicity,

and ease of handling, and to be economic enough for many units to be used in a single project.

In its fundamentals it is a subsurface, self-recording system, thus simplifying problems associated with the sea surface and with RF telemetering of data. The associated systems for calibration, data processing, and analysis do not differ much from other systems, but were arranged to make use of the available pieces of principal equipment rather than to require the designing of a complete, matched, sea-to-shore system.

The buoy system was conceived by the author in 1959 and developed, used, and improved at the Centre from 1962 to 1966. Although some components units have already been described in earlier reports (Refs. 1, 2, 3, & 4) the present report describes the complete system in its present form.

## 1. GENERAL DESIGN

The requirements of the buoy system were that it should be capable of making quasi-continuous measurements of ocean variables (temperature, current direction and speed, and depth as a first basis) at several depths down to the bottom, and that the records should be capable of easy computer processing. Moreover, the system had to be capable of operating as an independent unit for periods of up to one month.

So that many such units could be used by a single ship during one project, two other groups of factors had to be considered. One was that the system had to be simple to handle, reliable in operation, and flexible enough to be adjusted to suit the requirements of each particular study. This implied the use of miniaturized and standard components wherever possible. The other was that although prototypes and testing may be comparatively expensive, the final design should be comparatively cheap to reproduce. The increasing production of miniaturized products for the aerospace industries helped considerably in reconciling these two factors.

The design of the complete buoy system is a combination of compatible mechanical and electronic systems to permit the measurement, telemetering, and recording of data in adverse environmental conditions. As has been described in Ref. 4, the simplest electronic system was found to be that in which each measurement is made proportional to a time interval between two electric pulses. This has the advantage that the basic circuit of transducers is minimized,

that only a single conductor cable is required (sea return being used to complete the circuit), that a high signal-to-noise ratio can be obtained with minimum power consumption, and that the pulses can easily be recorded on a magnetic tape having a timed transport.

Thus the basic primary design required a single cable — which could serve as both the mooring line and the electrical conductor — suspended between a recorder-containing subsurface buoy and an anchoring system. Experience revealed that this basic design could be refined to give the required results (a history of these experiences is given in Ch. 8, and work continues towards further refinements). The buoy system in its present form is shown in Fig. 1.

Broken down into its components, the complete sea-going system consists of:

a. A subsurface buoy (B1) to provide the main support for a line of probes (Array 1) electrically connected to the instrument package contained in its tail. This package contains a programmer, a magnetic-tape recorder, a beacon transmitter, and the power supply.

b. A conductive mooring cable carrying a large number of electrically-connected probes (Array 1). It is made in sections that are easily connected in series to reach a maximum length of 500 m. The upper and lower ends of the array are separated from the buoys by swivels to reduce damage due to twisting.

c. A deep buoy (B2) to provide the main support for the mooring line.

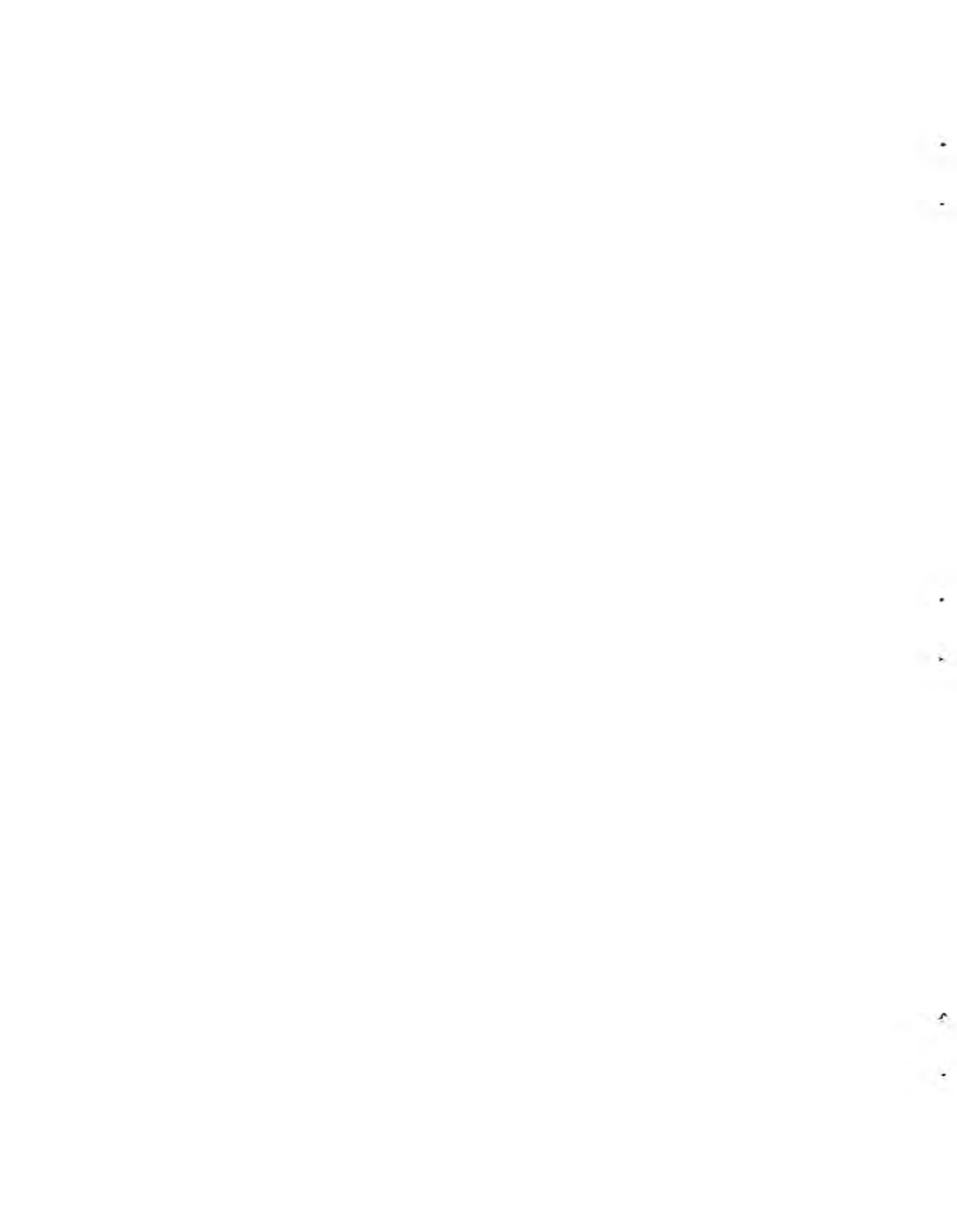
d. The mooring line, which can also carry widely-spaced, self-recording, neutrally-buoyant instruments that form Array 2. The mooring line is of uncovered, galvanized wire rope down to 1000 m (to resist fish bites) and of synthetic, self-buoyant rope below.

e. The recovery devices, consisting of an assembly of acoustic, clockwork, or corrosive systems.

f. The anchoring system, comprising expendable heavy and light chains, an anchor, and the retarding parachute used for soft launching.

These sea-going units are compatible with shore-based instrument assemblies that calibrate the probes and convert the data for computer analysis.

The following chapters describe the components according to either their electronic or mechanical aspects and give an account of how the unit operates in practice. A summary of several fundamentals is given in Appendix 1.



## 2. THE INTEGRATED UNITS OF ARRAY 1

### 2.1 Basic Circuit of the Transducers

The basic probe circuit, transducing the ocean variable into a proportional time interval between pulses, uses an R-C timing network. It has been described in Ref. 4 and is shown in Fig. 2, where the part marked C is common to all types of probes and the parts marked P, D, T, & V apply to the pressure, current direction, temperature, and current velocity sensors respectively. Its basic principle is that the time interval representing the measurement is between one pulse that is common to all sensors and the return pulse from each sensor's circuit. Fixed staggering intervals are added to each sensor's pulse return time so that they respond in sequence, from the shallowest to the deepest.

The measurement operation is explained in Fig. 3, in which the simplified circuit (b) represents the more complex circuits of Fig. 2.

Measurements are made intermittently in cycles, each of which starts when switch S 1 connects a battery voltage E to the insulated mooring cable and hence to the array of probes 1, 2, 3, ... n. The initial surge of current induces a voltage pulse  $P_0$  in the transformer TR, across which Channel 2 of a magnetic tape recorder R is connected. The start of the cycle is thereby recorded as a reference pulse from which all subsequent data pulses can be measured in terms of their time intervals.

The probe circuits are based on relaxation oscillators employing silicon unijunction transistors, as shown in Fig. 2 and illustrated schematically in Fig. 3b. When the cycle starts, and battery voltage is applied to the cable, the voltage across the capacitor  $C_1$  in each probe circuit starts to rise (Fig. 3c). As each capacitor's voltage  $V_c$  reaches the level  $V_p$ , its associated unijunction transistor  $Q_1$  fires,  $C_1$  is discharged, and a return pulse  $P_x$  ( $P_1$  being the return pulse from the first probe,  $P_n$  being the return pulse from the  $n^{\text{th}}$  probe) is sent back along the cable to transformer TR, where it induces a voltage pulse that is registered on the recorder.

For any probe (p), the time interval  $t_p$  between  $P_o$  and  $P_x$  (Fig. 3d) is therefore the time taken for the capacitor voltage  $V_c$  to reach the level  $V_p$ , this being dependent on the resistance  $R$  of the sensor, which is, in turn, a function of the ocean variable being measured. Thus, although all the probe circuits start charging simultaneously, they send back independent return pulses at time intervals  $t_1, t_2, \dots, t_n$  proportional to the measurement made.

Obviously, if the time intervals were strictly proportional to the measurements being made, it would be impossible to identify one type of measurement from another or to identify the order in which the probes were returning their measurements. However, the probes are "staggered" in such a way that all the pulses can be identified and that no pulse overlaps an adjacent one. Full details of this staggering technique are given in Ref. 4.



With the present probe circuits a set of 25 measurements can be made in cycles of about 10 sec each. The highest interrogation rate possible is at present two cycles per minute, because it is limited by the 20 seconds that capacitor C1 takes to return to zero voltage at the end of each cycle. However, interrogation rates of 1 cycle/min or 1 cycle/2 min have so far been used in practice. With the slower of these rates a recording life of about 25-30 days is obtained. The principle of operation could, however, be applied to electronics that permit shorter cycles and higher interrogation rates.

## 2.2 The Probes

Full details of the temperature and current measuring probes have been given in Refs. 4 & 5. It is sufficient here to refer to Fig. 4 for an illustration of their physical characteristics.

The pressure-exposed circuits of the first-generation probes have now been replaced by circuits enclosed in small, pressure-resistant containers to eliminate pressure-sensitivity effects from the measurements. These later circuits incorporate further miniaturization in their design, so that, on balance, the physical sizes of first and second generation probes are about the same.

Bourdon gauges have so far been used as pressure probes, but these have proved unsatisfactory and must be replaced by a type that will have higher resolution and greater accuracy and dependability.

### 2.3 The Programmer

The measurement programme described in Para 2.1 is controlled by a programmer mounted in the instrument package of Buoy B1 (Figs. 5 & 6).

The requirements for this programmer are that, with the utmost simplicity and economy of power, it shall provide the following:

- a. A basic stable frequency for counting the time interval between pulses with an accuracy approaching  $1:10^4$ .
- b. An "on-off" and delay switch system to command the various sequence stages of each cycle of measurements every 1, 2, or 3 minutes.
- c. A time mark every six hours.

The block diagram of the programmer is shown in Fig. 7a and the detailed circuit in Appendix 2. Of all the components, the only one that is in continuous operation — and hence drawing current — is the precise, battery-driven clock. This is a Bulova cycle-timer with a stable output of 360 Hz and an accuracy of about 1 sec per day (Appendix 3).

The operation of the programmer can be followed in Figs. 7b & 8. Once the required sampling rate (1, 2, or 3 min) has been set, the timer triggers Relay 1 at these precise intervals. Relay 1 then remains closed for the whole of the measurement cycle (shown as 20 sec on Fig. 7b, but this can be varied as required). The closing of Relay 1 switches on the motor (M) of the magnetic tape recorder through the closed Relay 3.

There is then a delay of 2 sec, which leaves a blank section on the magnetic tape for use during the playback process and also allows the recorder to reach a steady state. Relay 2 (a delay relay) then starts the measurement cycle by switching on power to the rest of the circuit. The 360 Hz of the timer are then recorded on Channel 1 of the tape recorder as a reference frequency. At the same time the start pulse  $P_o$  is sent down the cable of Array 1 and recorded on Channel 2 of the tape recorder; 32 ms later, and before the first return pulse from a probe, a test pulse  $P_x$  is recorded. The staggered circuits of each group of probes then send their individual return pulses, these being in sequence within each group from the shallowest to the deepest in the array, and the groups coming in the order: P (pressure), T (temperature), D (current direction), V (current velocity).

The end of the measurement cycle is marked by a stop pulse  $P_s$  generated exactly 10 sec after the start pulse. At the same time, Relay 3 (also a delay relay) opens and takes the power off the motor of the tape recorder, the array, and all other circuits.

The absolute time is established by 6-hr marks on the record. These are generated by a reset counter that receives its counts from a pulse generated by the opening of Relay 3. If the sampling rate is, for example, 1 min, the reset counter is made to operate after 120 openings of Relay 3; if the sampling rate is 3 min, 360 openings are required. At this time, Relay 4 switches off power from the array for one entire measurement cycle period and, instead, connects Channel 2 to the output of a 72 Hz generator. The 6-hr mark thus appears on the record as a fixed frequency replacing the data pulse series.

Provision is made for protecting the programmer's circuit from current overloads. If the external line of probes is accidentally short-circuited, the power to the array is cut off but the recorder continues its cycle of operations, thereby identifying the duration of the interruption. In practice it has been found that short circuits are usually from connectors and are of short duration, probably due to a temporary effect of the mooring motion.

The concept of a programmer as described has been to make it as simple as possible and to let the shore-based data conversion equipment do most of the work afterwards. In this way, power consumption, weight, and dimensions could be substantially reduced.

## 2.4 The Recorder

### 2.4.1 Specification

As has been seen, the data and reference pulses are recorded on two channels of a magnetic tape recorder. This is also mounted with the programmer in the instrument package of Buoy B1. (Fig. 5).

The recorder required for this system had to have the following specifications:

- a. High storage capacity,
- b. Simplicity of operation,
- c. Sturdiness and shock resistance,
- d. Minimum weight,
- e. Low tape speed (1 cm/s),

- f. Versatility —  $1\frac{1}{4}$  in. to 1 in. tape,
- g. Tape speed stability,
- h. Time compression during playback — by a factor of at least 50.

These specifications could only be reached by building a special model (Fig. 9). Only those parts indispensable to recording operations were retained, so that the recorder comprises only a tape-spooling mechanism and a tape-driving assembly.

#### 2.4.2 Tape mounting, drive, and tensioning

A rigid, anodized, anticorrosion, aluminium plate (530 x 220 x 8 mm) is used for the deck, and is secured to the PVC frame of the instrument package by shock mountings. Although the deck has to be rigid, the surface does not need to be precision ground.

The shafts of the capstan and spool rotate on high-accuracy ball-bearing assemblies that do not need lubrication between major maintenance overhauls. The spool shafts have grooves for lock-in washers to secure tape spools of 0.25 in., 0.5 in., or 1 in. width. An adjustable brake, which regulates the tape tension from the supply spool to the capstan, is made from a felt-lined disk and presses against the ball-bearing housing of the supply spool. The slip-clutch turns the take-up spool and keeps the correct tension on the spool capstan.

The adjustment of tape tension is a critical operation because the recorder operates intermittently and must use minimum time to stop or

reach the steady state. Furthermore, the unit must work in any position — including upside-down — and be capable of withstanding shocks without unreeling the tape. As full and empty spools have different inertia, simple mechanisms are inadequate.

Perfect alignment of the two spools is not needed, but the tape-loop drive and guide assembly must be precise. Thus, for economy and versatility, the latter assembly is mounted on a separate, precision-ground plate (120 x 70 x 6 mm) that fits on the rigid, but not precisely-ground, deck. Different assemblies — composed of pinch roller, adjustable tape-guide posts, and magnetic head of various manufacture — can be used to drive the three different tape widths. The tape loop size has been selected to satisfy space arrangements and the required tape-to-head contact.

The capstan is driven by an assembly consisting of a miniature, single-speed, precision motor and a set of reduction gears. The motor operates on 6 V dc, has 10 cm/gm torque, and turns at 3000 r/min (governor stabilized). It has a continuous operating life of up to 4000 hr using carbon brushes and a switching transistor arc-suppressor, accelerates and decelerates rapidly for quick on-off switching, and has a weight in air of only a few grams. The reduction-gear is a precision worm-wheel assembly with a 100:1 ratio. It was chosen to give smooth and rigid operation, as the choice of belts and joints may have introduced vibrations. The wheel of the reduction gear is of a clamp-on type to reduce eccentric effects. With this arrangement of the reduction-gear it is possible to place the motor horizontally.

When correctly adjusted, this assembly reduces the effects of uneven tape-reeling to within an acceptable range. Adjustment is made until a minimum and constant current load of  $70 \pm 1$  mA on the motor is reached. The motor is then adjusted — by its governor — until it is turning at 3000 r/min; thus the 2 cm circumference capstan is turning at 30 r/min and the tape is at the desired speed of 1 cm/s.

#### 2.4.3 Magnetic Head

The magnetic record-play head has the following specifications: two-track stereo, laminated with hyperbolic face not requiring pressure pads for good tape contact, 160  $\mu$  in. gap, 0.080 in. track spacing.

The gap permits clear reproduction of wave lengths down to 300  $\mu$  in. (approx 77  $\mu$  m), giving 1300 Hz/cm at a constant tape speed of 1 cm/s. A pulse-packing density of 1000/cm has proved dependable with this recording system.

Head adjustments are important and provision has been made for face, height, and azimuth alignment. During speeded-up play-back the head must be adjusted until the maximum signal amplitude is reached.

So far, the 0.25-in.-wide tapes — particularly the thin-based, long-playing type on 10.5-in. spools — have been used in the system. However, when the transport is made intermittently, these tapes can be easily damaged by excessive tension or their inherent elasticity can produce unstable transport; a standard tape is more dependable

when the system is used for less than two weeks or not at full capacity. Laboratory tests with double length, double strength, 88 mil (coating and backing) thickness — which permits closer tape-to-head contact — have given satisfactory results.

(Recording time with a tape speed of 1 cm/s is given by the formula:

$$T = \frac{L}{C_h} \times 10^2$$

where      T = number of days,  
            L = length of tape in metres,  
            C = duration of cycle in seconds,  
            h = rate of interrogation per day.)

The recorded data are processed ashore by the Data Conversion Unit described in Ch. 5.

## 2.5 Power Supply

The power supply, which is adequate for the required number of measurements, is also contained in the instrument package of Buoy 1. It consists of various sections of mercury batteries, each section being used to power one of the devices.

## 2.6 The Conductive Mooring Cable, its Swivels and Joints

### 2.6.1 The cable

The conductive cable of Array 1 shares with the non-conductive cable of Array 2 all the mechanical stresses and motions of mooring the



buoy system. These aspects will be discussed later; here, however, only the electrical properties will be described.

The electrical requirements of this cable are that it should be a well-insulated single conductor (sea-return being used to complete the circuit) to which outlets for the probes can be rapidly moulded. A neoprene-insulated steel wire was chosen, the full specifications of which are given in Appendix 4.

The outlets for the probes have been specially designed and can be applied and vulcanized onto the neoprene cable in a few minutes in the field as desired. The design of the outlets also incorporates a mechanical system for clamping the probes to prevent them from turning around or sliding along the cable. A diagram of the outlet and its clamping system is given in Fig. 10.

#### 2.6.2 The Conductive Swivel

The conductive swivel used to connect the cable of Array 1 to Buoy B1 has been described in detail in Ref. 3.

#### 2.6.3 The Conductive Joints

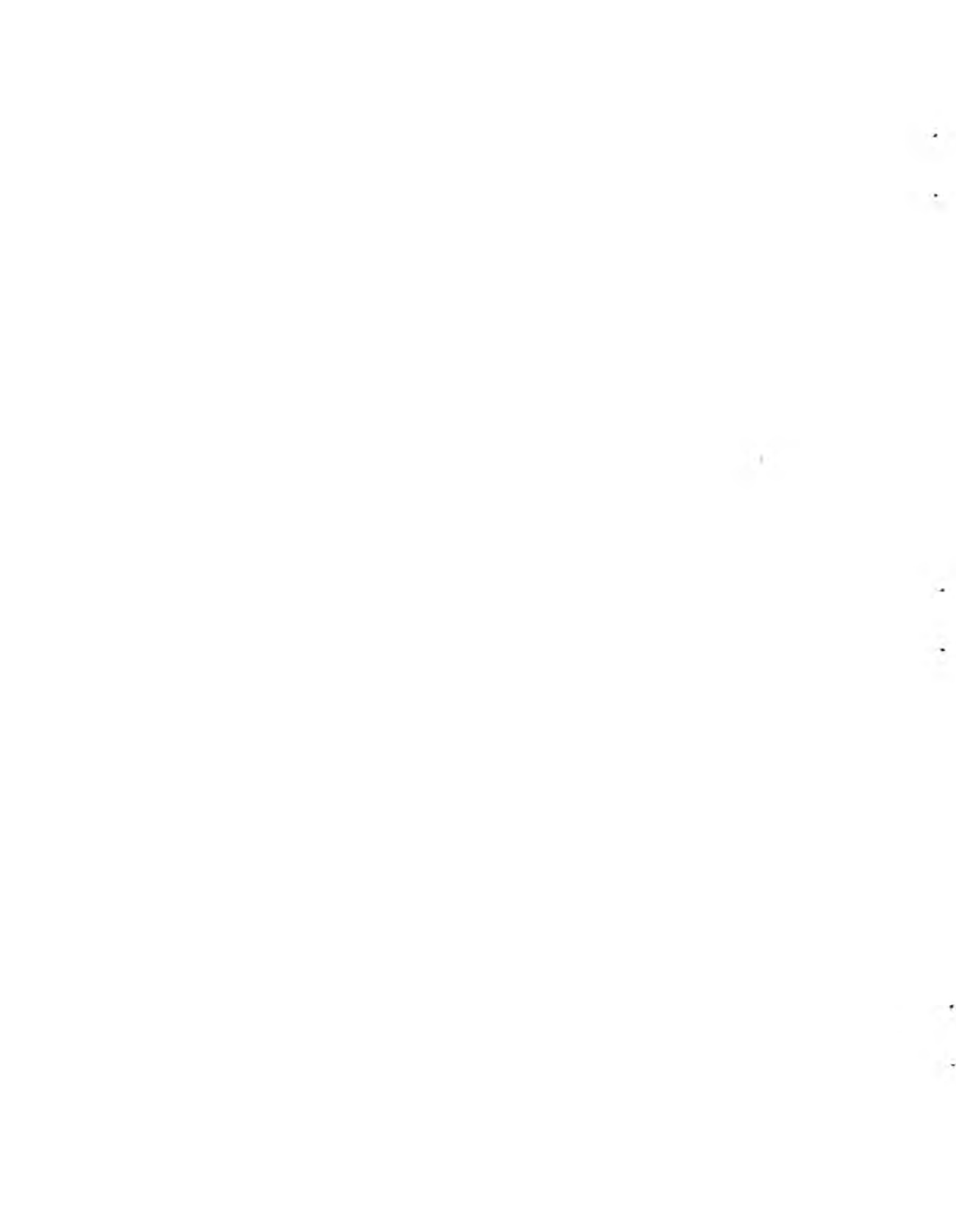
As it is convenient to break up Array 1 into increments of 50, 100, and 200 m lengths — thereby allowing greater flexibility in assembling an array for a particular use — special conductive joints have had to be designed.

These are shown in photograph and cut-away drawing in Fig. 11. They are pressed on the wire of the conductive mooring cable by means of a 'Tallurit' portable hydraulic press and moulded to the neoprene insulation of the cable by a portable vulcanizer. The mechanical connection is made by two cup-shaped screw joints that fit snugly around the insulated terminals. Precise fitting eliminates the chance of damage by cable flutter or vibration.

### 3. THE INDEPENDENT UNITS OF ARRAY 2

The independent current meters of Array 2 were derived from the current probes developed for Array 1. The probes themselves are mechanically identical but make continuous recordings on miniature, self-contained recorders contained within an adjacent glass sphere. The complete unit — consisting of a current velocity meter, a current direction meter, and the recorder/power supply pack — is illustrated in Fig. 12 and described in detail in Ref. 5.

Calibration of the probes themselves and conversion of the data obtained from these meters are the same as for Array 1; Chapters 4 & 5 provide the details.



## 4. THE CALIBRATION OF PROBES

### 4.1 Thermometer Probes

The calibration is made semi-automatically with the equipment shown in Fig. 13. The probes are suspended in a bath that is heated and controlled by a Fisher Temperature Control Unit associated with a Rosemund reference thermometer (a platinum resistance thermometer calibrated at the U.S. Bureau of Standards) and a precise Mueller Bridge. As the bath had no cooler it was kept within a refrigerator. Sensitivities of the order of  $0.001^{\circ}\text{C}$  and accuracies of  $0.005^{\circ}\text{C}$  are obtained.

Several measurement cycles are made on a batch of probes at as many temperatures as are needed for drawing calibration curves within the desired temperature range (calibration curves are considered to be linear between points). At each temperature several measurements are made in sequence until steady state — which depends on the time constant of the probes — is achieved. This can be seen on an oscilloscope (not shown in Fig. 13). The calibration measurements are punched on paper-tape for later use in the automatic correction of raw data before analysis.

### 4.2 Current Probes

The current probe circuits can be calibrated quite simply. The velocity probe circuit is checked at pulse frequencies corresponding to known rotor revolutions, and hence to given speeds. The direction probe circuit is checked by varying a  $2000\ \Omega$  rheostat to correspond

to the potentiometer values of the instrument.

The calibration of these probes is actually more concerned with the mechanical adjustment of the instruments than with the electronics.

The method of carrying this out has been explained in Ref. 5.

#### 4.3 General

The calibration curves of the standard electronic circuits of the probes are unfortunately not perfectly exponential and a suitable number of calibration points must therefore be established. For computer data-processing it would be more desirable for these curves to be exponential; this is something to be considered for further improvement of the system.

Repeated calibrations made at intervals of several months and over total periods of up to two years indicate that the long-term stability of the circuits is now good in the majority of cases. Field and calibration experience with the first batch of probes demonstrated that the use of components with low temperature-sensitivity could greatly increase the reliability of the circuits. Later experience also showed that pressure-sensitivity could best be eliminated by enclosing the whole circuit in small pressure-resistant containers, rather than relying on the characteristics of the individual components.

## 5. DATA CONVERSION

### 5.1 Data from Array 1

The data recorded as pulse series on the magnetic tape must be converted for use by the computer. The data conversion system used until now is shown in Fig. 14. However, experience has shown that it could be greatly simplified and the reliability thereby increased.

The magnetic tape from the buoy is played on a tape recorder at four times its recording speed (i.e. at 4 cm/s). Because cycles are recorded in sequence, with a minimum of tape loss between them, the actual play-back time is much less than a quarter of the total period covered by the measurements. For example, when the interrogation rate is 3 min and when each cycle lasts 12 sec (12 cm tape), the play-back time can be fifty times shorter than the field recording time; thus one month's recordings can be converted in about fifteen hours. It is expected that future systems will improve this ratio.

The outputs of the tape recorder (reference frequency and data pulses) are filtered and shaped, observed in an oscilloscope, and fed to a cycle-counter. A visual display is obtained on an L & N recorder that has been converted to record short pulses by means of an electric stylus and electrosensitive paper (Ref. 2). The punch-tape reader and counter/printer unit is often used to check interesting sections of the records before computer analysis.

Programmes for data handling, editing, calibration, and display have been written and applied. Figure 15 shows an example of some data

from Array 1, as plotted by the computer's X-Y plotter. The buoy system was moored at the eastern entrance to the Strait of Gibraltar in September 1965 and recorded for 17 days. The example shows 14 hours of these recordings. In this case Array 1 was quite simple and carried only the following probes:

<u>Distance below Buoy B1</u>	<u>Probe</u>
10 m	( Depth (P) ( Temperature (T)
40 m	( Current Direction (D) ( Temperature (T) ( Current Velocity (V)
90 m	( Current Direction (D) ( Temperature (T)
140 m	( Current Direction (D) ( Temperature (T) ( Current Velocity (V)
200 m	( Current Direction (D) ( Depth (P) ( Temperature (T) ( Current Velocity (V)

It should be noted that the distances shown on the left-hand side of Fig. 15 indicate the distance of the probe along the cable from Buoy B1, and are not indicative of the true depth, the fluctuations in which are recorded by the changes in the P trace.

The measurements were made every 3 minutes, in the order shown in Fig. 15 (reading from top to bottom). The plot is therefore built up of a vertical sequence of points that eventually combine to produce the horizontal traces shown.



The scales on the right-hand side of Fig. 15 indicate the ranges of variation of each parameter: the D traces range around the points of the compass, the P traces range from shallower depths above to deeper depths below, the T traces range from higher temperatures above to lower temperatures below, and the V traces range from slower speeds above to faster speeds below.

One of the features shown is the rhythmic vertical motion of the array, as indicated by the two 'P' curves, which rise and fall almost in phase.

Another feature is the apparent passage of four high-amplitude internal waves, followed by a few decaying ones, shortly after the current reversal in the upper layers (40 m - 90 m), which occurred just after the 19.30 Low Water at Gibraltar.

## 5.2 Data from the individually self-recording instruments of Array 2

The current meters of Array 2 record on a paper trace, as described in Ref. 5. The curves representing the continuous records of direction and velocity (plus pressure and temperature traces, if these probes have been added to the units) are visually interpreted, smoothed, and digitalized at suitable time-intervals to obtain a tape for analysis by the computer. This work could now be carried out with the Centre's D-Mac pencil-follower.

## 6. THE MOORING ASSEMBLY

### 6.1 General

The mooring assembly shown in Fig. 1 comprises the mooring line in its various sections, the supporting buoys, the anchoring system, and the anchor releasers. The choice and design of its present mechanical arrangement is the result of the many conflicting requirements and the availability of components on the market at acceptable prices. Miniaturization, low-drag, flexibility, simplicity, dependability, and ease of handling have been the basic requirements.

### 6.2 The Mooring Line

The present mooring line arrangement, far from having reached the most satisfactory solution, is the best compromise so far obtained. It has undergone many modifications as the result of field experience.

The principal mechanical specifications are:

- a. Low weight in water,
- b. Small cross-section,
- c. High tensile strength,
- d. Low radius of curvature,
- e. Non-twist,
- f. Flexibility,
- g. Durability,
- h. Quick instrument clamp-on.

In addition, as has been seen in Ch. 2, the upper section of the line also has to have certain electrical characteristics.

The present arrangement is that the mooring line is made up of three different kinds of rope:

a. A neoprene insulated 5.5-mm-diam wire rope having a breaking strength of 0.9 ton and a weight in water of 42 gm/m. This is the cable of Array 1.

b. An uncovered 3.2-mm-diam double galvanized wire rope having a breaking strength of 1.2 ton and a weight of 50 gm/m. This is the rope of Array 2.

c. A synthetic self-buoyant rope below.

The reasons for the choice of the upper, insulated rope have already been explained in Ch. 2. The uncovered wire rope was chosen for the middle section because it has low drag, will resist fish-bites, and provides a stable support for the self-recording current meters. Below 1000 m, hydrodynamic drag is less critical, fish bites are not experienced, and synthetic rope can be used to reduce the total weight of the mooring line.

The two types of wire rope are used in section lengths that can be connected in series by means of the miniature joints and swivels described in Ref. 3. With the present system and materials the rope of Array 1 should not exceed 500 m and that of Array 2 a total of 50 kg weight in water. Further miniaturization of the probes and instruments may improve these limitations.

Experience has shown that when surface currents exceed 1.6 kn the upper 50 to 100 m of Array 1 offers too much drag, begins to flutter, and causes an undesirable dipping of the buoy. Tailor-made, neutrally-buoyant fairings that can easily be clamped to the line should be designed to overcome this problem.

Studies of mooring line motion and of cable vibration and torque are given in Appendices 5 & 6 respectively.

### 6.3 The Buoys

#### 6.3.1 Specifications

The buoys -- which, as shown in Fig. 1, consist of the upper buoy B1 and the lower buoy B2 -- had to be designed to keep the mooring line as nearly vertical as possible, even in regions of high currents; their main requirement was therefore a high lift/drag ratio.

Experience has shown the need for unsinkable buoys that would enable the data and instruments to be recovered if the buoys or the cable were accidentally damaged. Since 1964, the availability of Klegencell, which is an expanded and hardened plastic that is resistant to water pressures, has made it possible to satisfy this requirement. The material is available in various densities for use at various pressures, up to a present maximum of  $0.3 \text{ gm/cm}^3$  density for use at  $600 \text{ kg/cm}^2$  pressure (600 m depth). It is manufactured only in 3 to 4 cm plates, either as 30 cm circles or as 50 cm squares. The first type suited the design requirements of buoy B1 because of its high

finesse ratio, but for buoy B2 the more economical square plates were adequate.

### 6.3.2 Buoy B1

This buoy, shown in Fig. 16, keeps Array 1 taut and supports within its own structure the neutrally-buoyant instrument package containing the major electronic equipment for Array 1.

It is made of a stack of Klegencell plates supported by a central tube of stainless steel that is sealed at both ends to reduce its weight in water. With a 6.0 cm O.D., 5.3 I.D. tube the stack of plates can reach a maximum length of 4.5 m, giving a net lift of about 220 kg. In the present buoy, the stack is only 3 m long (75 plates) and gives a net lift of 145 kg.

The central tube also gives strength to the long lifting body, supports the front recovery hook, and, by means of a welded tripod, carries the weight of the instrument package when the buoy is out of the water.

The stack of plates is covered by a smooth PVC shell that reduces skin drag and damage to the plates. The nose and tail are identical ogives; these have so far been made of PVC, but neoprene would be more durable. The tail ogive carries horizontal and vertical fins for alignment of the buoy.

A stainless-steel mooring collar, by which Array 1 is supported, slides over the shell and is positioned at the centre of buoyancy of the buoy, (which varies with the contents of the instrument package). The mooring ring swings freely from stainless-steel mooring points welded to the collar slightly below the centre of buoyancy, thereby giving greater static stability to the buoy. A balance weight gives stability when on the surface and thus keeps the beacon transmitter's antenna out of the water.

The steel instrument-package container (Fig. 5a) is bolted to a tripod at the end of the central tube. It has a rear access hatch for the removal of the instrument package; this hatch has six bulkhead electrical connectors and also carries the stainless-steel whip antenna for the beacon transmitter. The sealed container has a maximum operating depth of 220 m; for neutral buoyancy it has a payload capacity of 23.5 kg, which is more than enough for the weight of the tape recorder, programmer, power unit, beacon transmitter and their supporting PVC shell (a total of 16.7 kg).

### 6.3.3 Buoy B2

This buoy, which is attached to the bottom of Array 1, supports Array 2. It thus operates at depths between 200 and 500 m where the hydrodynamic problems are not as severe as they are for Buoy B1. However, it was proved that a faired buoy that aligns itself with the currents can reduce unwanted mooring motion.

Sphere cells can be used if the currents are small and the required lift is high. However, as with buoy B1, since 1964 the use of

Klegencell plates has been preferred. At this depth the  $0.3 \text{ gm/cm}^2$  - density plates should be used. The principle of construction is the same, but the cheaper square plates can be used for this buoy if they are faired with a simple arrangement of plastic sheets. The only instrument that has to be carried in the buoy is the beacon transmitter. Figure 17 shows the buoy being launched.

At various stages in the development, unfaired spar buoys with marker balloons (which collapse under pressure at depth) or lens-shaped pre-pressurized buoys were used for buoy B1 (these are shown in Fig. 18 a & b), but it was found that the unsinkable faired buoy was better in the Strait of Gibraltar because of its reduced drag.

#### 6.4 The Anchoring System and its Releasers

The anchoring system permits soft launching and setting on the bottom and a good grip of the sea floor. Experience has shown that a heavy length of scrap chain (300-450 kg) is suitable to counter-balance the lifting forces of the buoys and to give the required anchoring softness. It has high density, is easy to handle on deck, and is expendable. The type of gripping anchor (15-30 kg) used is selected to suit the bottom.

As recovery of the chain and anchor is unpractical with a system that is already working on the fringe of engineering tolerance, these are abandoned at the end of each measurement period by means of a system of anchor releasers. Several types are available - acoustic (Ref. 1), clockwork, or corrosive - and these should be used in conjunction to reduce the risk of failure. The selection of releasers may allow recovery on command or it may set recovery for a fixed time.





## 7. MECHANICS: HANDLING AT SEA

### 7.1 Storage

The buoys, anchoring system, and the rigging for lowering overboard are generally kept aboard ship. Two men can easily handle this equipment piece by piece.

The instruments, probes, and cables are generally returned to the laboratory after each use so that they can be maintained and calibrated. Each of these items can be carried by one man.

### 7.2 Launching

The 4-to 5-m-long Buoy B<sub>1</sub> is slung over the ship's stern on a trapeze (Fig. 16b) from which it is released by pelican hooks. As the ship drifts or steams away, a double line around the recovery hook tows it at the proper distance (a safety measure in areas of heavy traffic, such as the Strait of Gibraltar) while the instrument array is streamed out through a special roller block (Fig. 19) that will pass shackles, thimbles, terminals, and the small-size thermometers. The larger meters and other equipment are clamped on after their clamp-on fittings have passed the roller block. The operation is preferably carried out on the fantail and the cable unreeled from a variable-speed cable spool driver.

Just before the B<sub>2</sub> Buoy — hanging overside on a long pelican hook — is connected to the line and let free, the B<sub>1</sub> buoy is released from its tow line. This keeps Array 1 under tension between

the two buoys and allows the swivels to unwind any dangerous twists. Array 2 is now eased out more rapidly and its end shackled to the anchor releasers and anchor system that are already hanging overside awaiting release.

Once the mooring line is properly streamed, the anchor assembly is released. The sinking of the anchor assembly (which weighs up to 350 kg) is reduced to 1 m/s by a small parachute (Army disposal). As the anchor is released, the buoys are seen to be towing through the water at about 2 to 3 kn and their beacon transmitters are heard until they submerge.

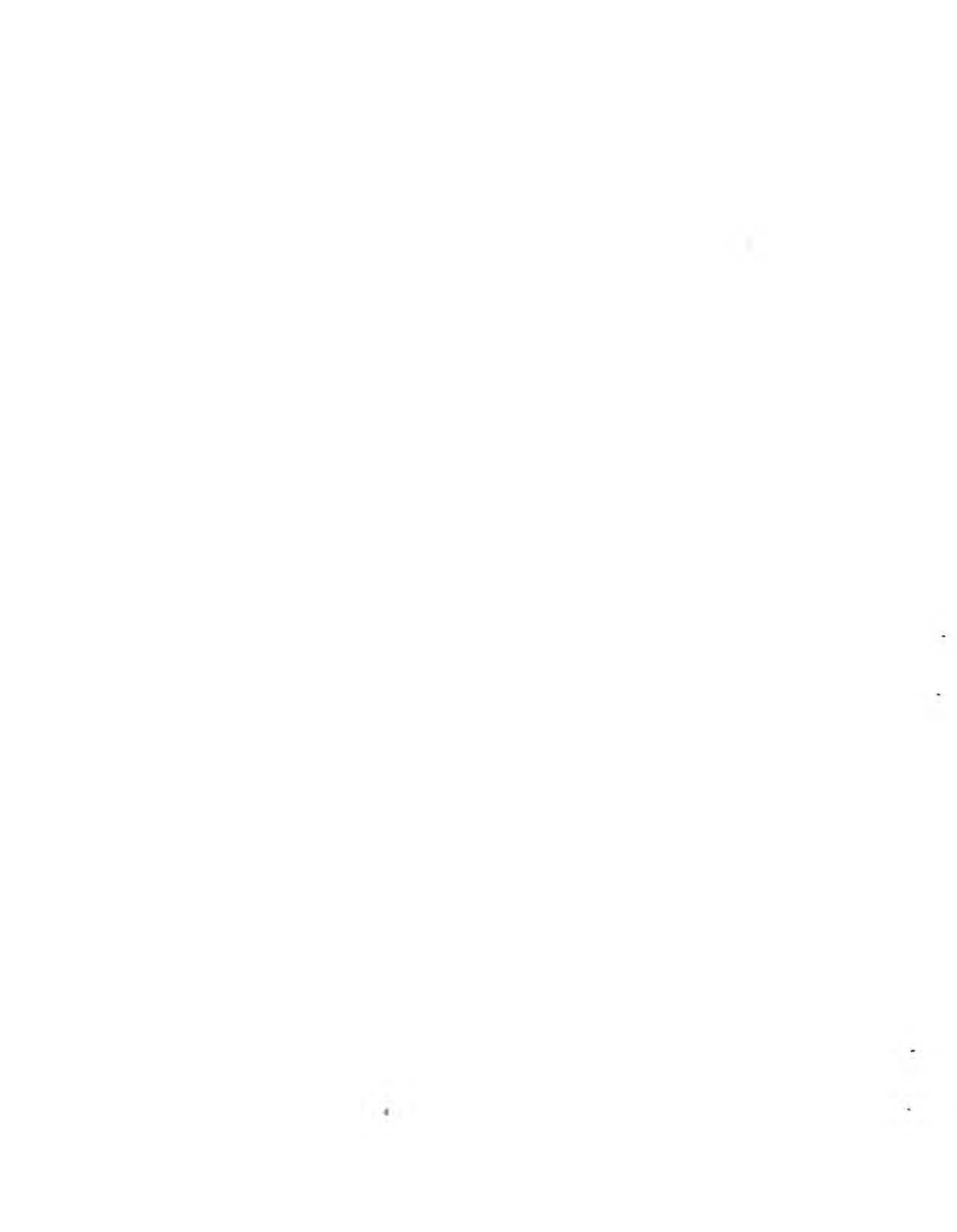
By using this method of launching, damage to the instruments has been minimized. Several 1000-m-deep stations have been set in this way in the Strait of Gibraltar (where surface currents of 4 kn are found) in somewhat less than one hour each, including the electrical tests of Array 1.

### 7.3 Recovery

On being released from the anchor (or being torn from their moorings by rough seas or human agency), the buoys rise to the surface and their beacon transmitters automatically switch themselves on. The beacon transmitter now being used transmits on a 27.085 MHz carrier frequency with a 1 W output at the antenna. This allows the ship to move as far as 50 n.mi from the furthest buoy when operating with many buoy systems at the same time.

The signal is received by a crystal-controlled receiver alarm on the ship's bridge and the buoy is then tracked down by DF. Upon spotting the buoys, the ship manoeuvres to pick up Buoy B1 first. This is done by means of the specially-shaped hook on the nose of the buoy and the buoy is placed in its cradle on the deck. The top of Array 1 is disconnected from the buoy's bridle, snap-hooked to a pendant run out from a variable-speed spool driver, and reeled in. The operation is then the reverse of that for launching. The ship is steamed to keep the line of instruments just slack enough for fast retrieval.

As the current meters of Array 2 are brought in, they are removed from the cable, washed in fresh water, dried with compressed air, and stored for extraction of their data, calibration, maintenance, and further use.



## 8. RESULTS

### 8.1 Field History of the Buoys

From 1962 to 1966 several generations of buoys were evaluated and used during six test trips and six survey trips. The progress made in subsequent generations was in increasing simplicity, reliability, and sturdiness.

From 1962 to 1964 the buoy system consisted of a sub-surface buoy with an array of instruments down to the bottom of the ocean and a surface marker-float with a 'Citizen band' RF transmitter. These buoys were retrieved by pulling on the cable and breaking a weak link near the anchor.

From 1964 to 1966, in the Strait of Gibraltar, because of the intense traffic and the high currents, the system was made of two subsurface buoys with the array of simultaneously recording probes tensioned between them.

8.1.1 In January 1962 the first test was made in shallow water (100 m depth) to check the feasibility of the mechanical system and to test the launching and anchoring methods.

8.1.2 In June 1962 the first system, provided with thermometer probes on a 400 m. long array from surface to bottom was anchored in a deep channel between Corsica and Capraia where currents exceeding one knot from surface to near bottom are found. Electrical noise was experienced on the records collected, but the mechanical system appeared efficient for a 36-hr operation.

8.1.3 In January 1963 tests of auxiliary electronic equipment were made. The acoustic anchor releaser (Ref. 1) operated successfully, releasing a buoy anchored at 100 m depth. The use of a continuous narrow band signal of 1400 Hz appeared effective and preferable to a coded signal, which was received distorted by reverberation in shallow water (100 to 300 m depth). A 37 MHz, standard 100 MW transmitter was tested for recovery use as a beacon transmitter, and for transmitting data from the submerged buoy. The range for efficient reception appeared to be no better than two miles.

8.1.4 In April 1963 the first operating buoy was anchored in a narrow channel 400 m deep at the sill depth of the Strait of Sicily. The surface float carried a miniature radio transmitter and radar reflector and had the shape of a small boat. The array of thermometers extended from the surface to the bottom. Some damage to the cable—a wire rope insulated with polyethylene—caused a very noisy record from which the signal could not be filtered successfully. A better cable had to be designed.

8.1.5 In June 1963, diver inspection of the behaviour of the buoy exposed to tidal reversing currents of the order of 0.5 to 1 kn was made with a buoy anchored in 30 m of water very near to shore. Despite local notice to mariners and signs of danger, a fast motorboat accidentally hooked the surface marker and broke the weak link of the anchor. The buoy was recovered adrift. It was then decided that surface markers were undesirable.

8.1.6 In October 1963 three buoys were launched in deep water near the sill region of the Strait of Sicily as part of a survey. One system was recovered with nine days of recording; one did not withstand a three-day gale and was recovered adrift one month later; the third buoy withstood the gale very well but was probably taken by fishermen while the ship was 30 mi away. From this operation it appeared that the catamaran low-drag surface floats were not effective, as they were found reversed after the gale. A spherical, inflated orange-coloured float with a vertical stick appeared to be the most effective and stable surface marker float, but was too attractive to fishermen.

Radio-transmitted pulses were never received successfully. In order to receive a reasonable signal it was recognized that the power output at the antenna had to be at least 1 W, which would also extend the range beyond the line of sight.

8.1.7 In January 1964 a new cable was obtained, which had a neoprene insulation. A simplified programmer, improved tape recorder, and more reliable electronic circuits were evaluated near Corsica, using an array suspended from the ship. Cable vibrations were recorded on this occasion. Submerged floats were also tested. Consequently three systems having arrays 700 m long were prepared for tentative use in the Strait of Gibraltar.

8.1.8 In September 1964 three buoys were successfully anchored in a triangle at the eastern entrance of the Strait of Gibraltar to record temperatures and currents over a period of 20 days. At the end of this period the acoustical anchor releasers failed to operate.

A contemplated alternate time-delay releaser had not arrived in time for the operation, so that there was no other way of releasing them. The acoustical releaser includes an inhibitor to eliminate unwanted triggering by ambient or ship noise (Ref. 1), and one of the reasons for the failure could have been the local high noise level, which would have permanently inhibited the triggering mechanism. Attempts to drag the buoys with mine-sweepers failed. The deep-mine-sweepers could identify some of the buoys on their sonar but their heavy sweeping gear could not operate safely because of the contrasting currents in the lower water layers. The three buoys had to be considered a total loss. As a result of this experience, the two deep floats were made unsinkable and both time and corrosion delay systems were in future used in the Strait of Gibraltar for releasing buoys from their anchors. Several of them in parallel were needed to decrease the probability of failures.

8.1.9 In March 1965 a low-power-consumption pinger of the type used in Swallow floats was incorporated in a test buoy and tested at a depth of 100 m in the Ligurian Sea. It appeared to work satisfactorily. In order to use this acoustical system for locating the buoy and to check the buoy operating conditions, the pinging was triggered by the pulses arriving at the input of the tape recorder inside Buoy B<sub>1</sub>. The method appeared to work in the shallow water of the Ligurian Sea, but when tried in the Strait of Gibraltar the system proved unpractical; by the time the ship was put in silent condition it had drifted too far with the surface currents, which can be as high as 5 kn. The signal from the pinger was never identified and the listening hydrophones on the drifting ship were recording a lot of noise.

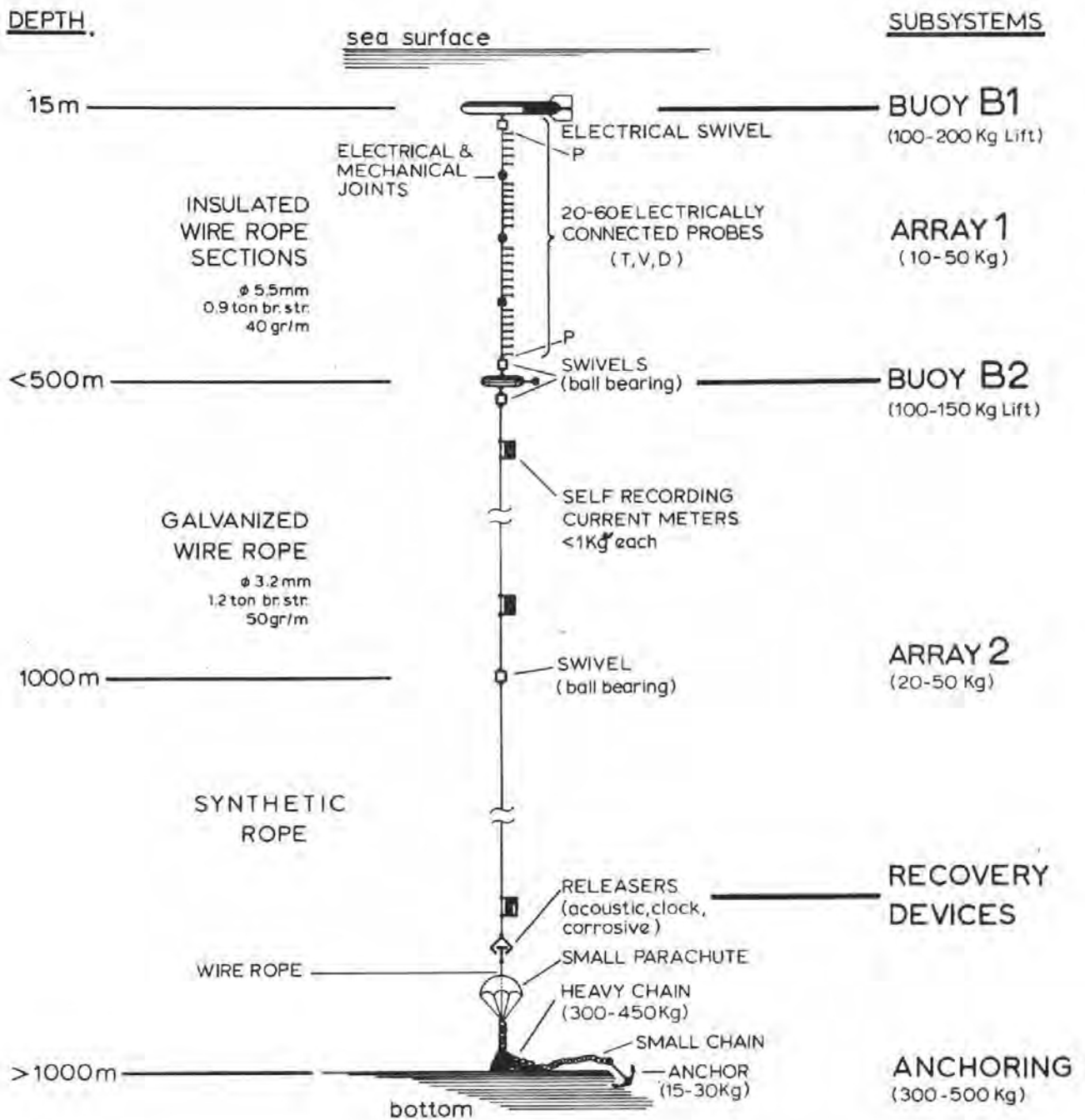


8.1.10 In April 1965 only two buoys were available. They were successfully launched and retrieved five times. On four occasions, records of one day each were obtained, and on one occasion a useful record of 17 days was produced. Further simplification was made on the programmer after this experience and a time-marker was introduced for double-checking the absolute time control.

8.1.11 In August 1965 one buoy was anchored twice. The useful records were only two hours in the first launching and 20 hours in the second. In each case the buoy returned to the surface unintentionally. The cable was found cut at 2 m below the upper buoy on one occasion and at 140 m depth on the other. The rest of the arrays were recovered, being brought back to the surface by the lowest buoy when the delay-time releasers worked at the time for which they were set. Where the cables were cut, the individual strands were found untwisted and the break suggested that the failure was due to torque fatigue. The three-spire cable used is not completely non-twist in practice. When subject to torque action of the buoys, and flutter, vibration, and some twist during the launching and anchoring phases, a few strands start to weaken and break, causing a rapid failure under tension. Swivels improve the system, but a better torque-free cable is needed.

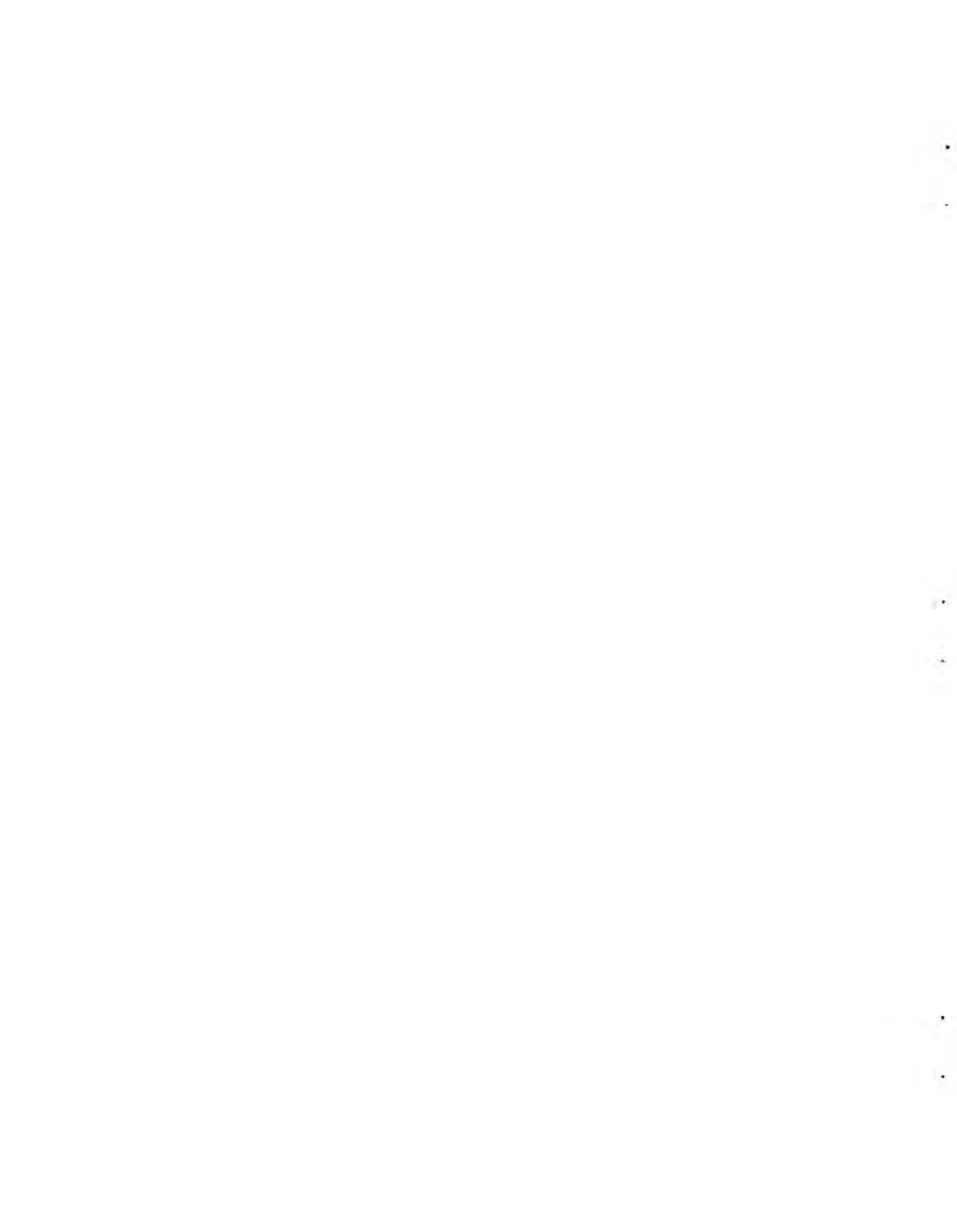
8.1.12 In January 1966 two more buoys were moored in the Strait of Gibraltar; these had the electronic circuits of the probes encased in a metal cylinder to eliminate pressure-sensitivity effects on the measurements. Both buoys were anchored in difficult conditions, due to disapproval by the Spanish Government, and were lost at non-determined times. Seventy-five knot winds prevented ships and

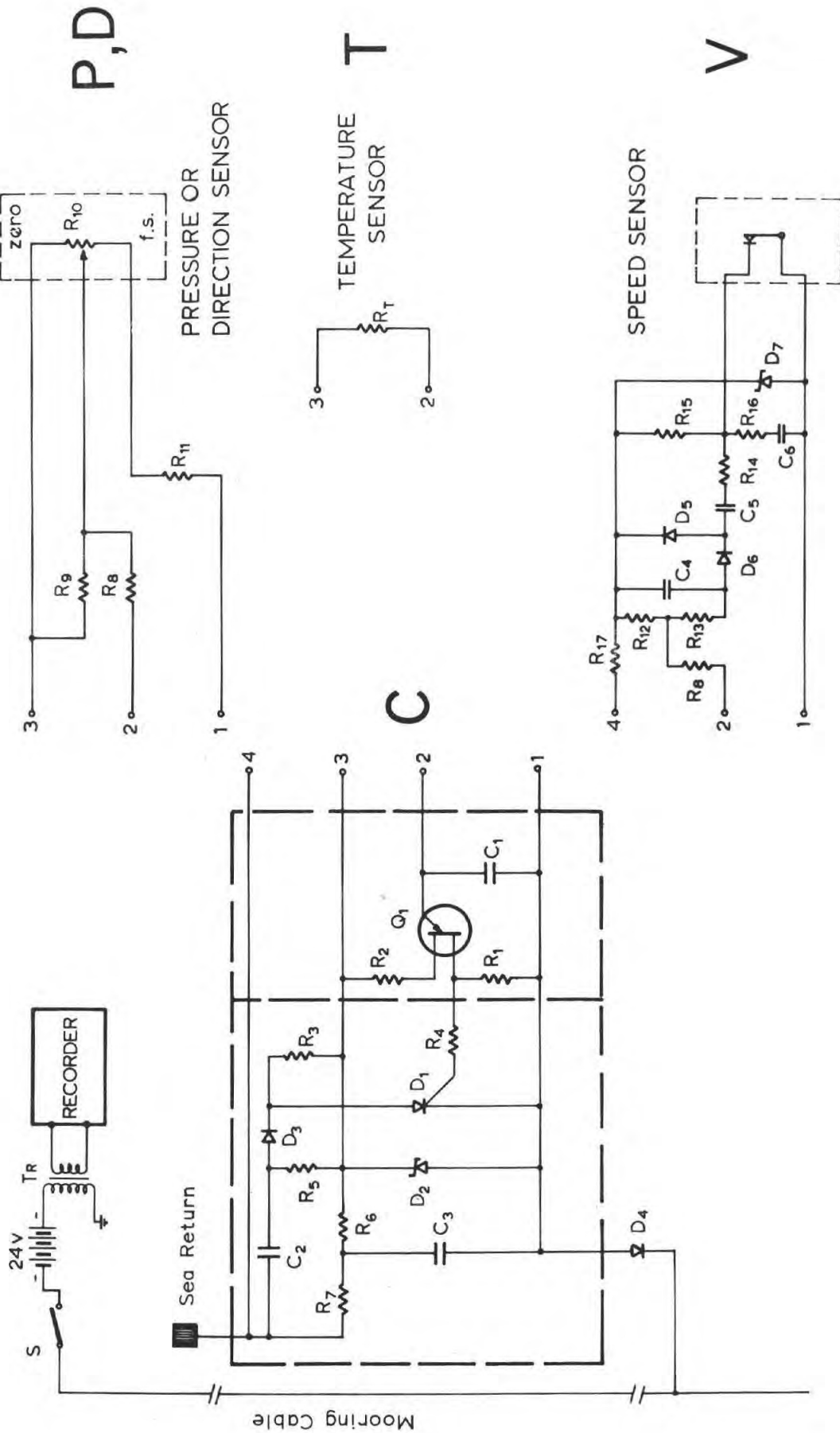
aircraft from locating the buoys. One was subsequently found on the Algerian coast and was returned through diplomatic channels. This experience indicates that "Oceanographic Buoy" marks and the address of the owner should be indelibly marked on the buoys, and that a letter should also be enclosed within the instrument container of buoy B1.



**FIG. 1 MOORING SYSTEM**

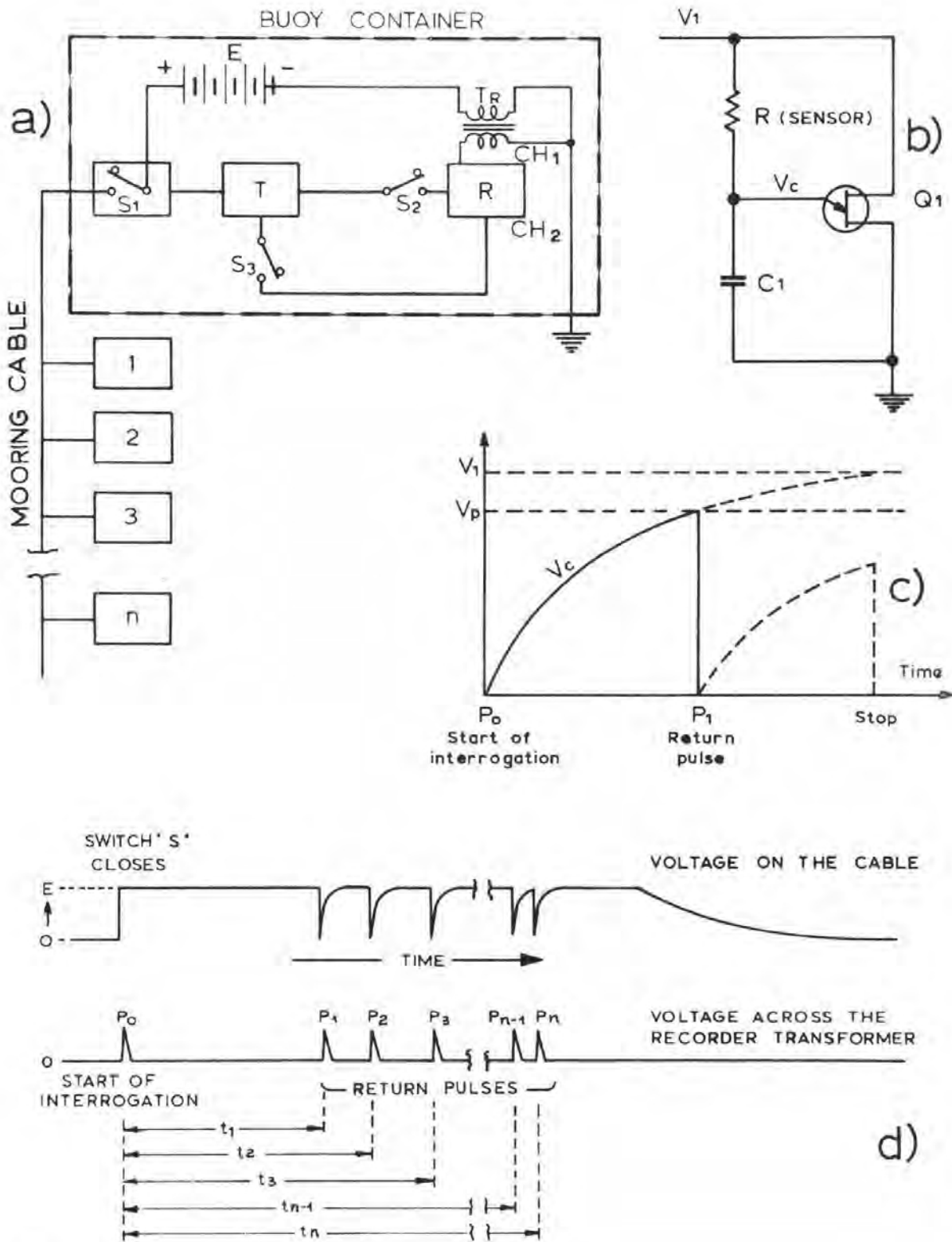
AN ARRAY OF CLOSELY SPACED PROBES MEASURING TEMPERATURE, CURRENT DIRECTION AND VELOCITY, AND DEPTH FORM ARRAY 1, WHICH IS KEPT TAUT BETWEEN BUOYS B1 AND B2. THEY RECORD UPPER-LAYER MICROSTRUCTURES SIMULTANEOUSLY ON A MAGNETIC TAPE RECORDER IN B1. WIDELY-SPACED, SELF-RECORDING CURRENT METERS, CLAMPED COAXIALLY TO THE LOWER LINE, FORM ARRAY 2.





**FIG. 2 BASIC CIRCUIT OF THE PROBES**  
 CIRCUIT C IS COMMON TO ALL TRANSDUCERS AND TRANSFORMS A VARIABLE RESISTANCE OR VOLTAGE FROM THE DIFFERENT SENSORS INTO A TIME-INTERVAL BETWEEN PULSES.





**FIG. 3 ELECTRONIC PRINCIPLE OF THE PROBE SYSTEM**

- (a) CIRCUIT OF BUOY CONTAINER  
 (b) SIMPLIFIED PROBE CIRCUIT (see Fig.2)  
 (c) VOLTAGE BUILD-UP OF CAPACITOR  $C_1$  WHEN VOLTAGE  $E$  IS APPLIED TO THE MOORING CABLE AND PULSE  $P_0$  INITIATES A SET OF MEASUREMENTS  
 (d) THE SEQUENCE OF PULSES GENERATED BY THE UNIUNCTION TRANSISTORS  $Q_1$  OF THE DIFFERENT PROBE CIRCUITS

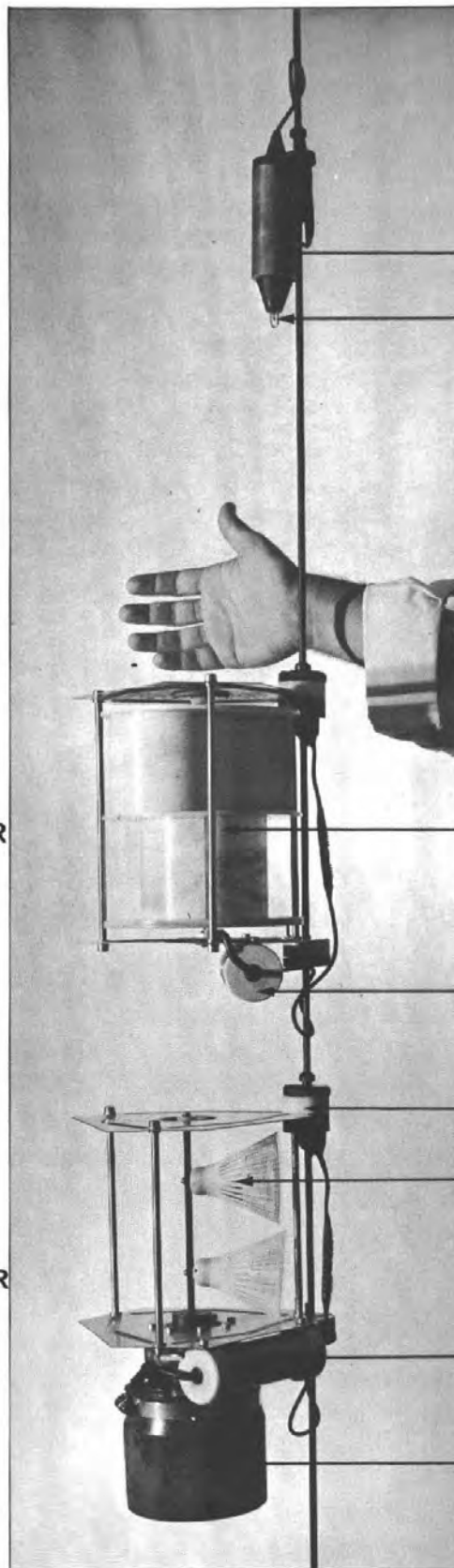




**T**  
THERMOMETER  
(60 gm)

**V**  
CURRENT  
VELOCITY METER  
(550 gm)

**D**  
CURRENT  
DIRECTION METER  
(850 gm)



Circuit  
Thermistor

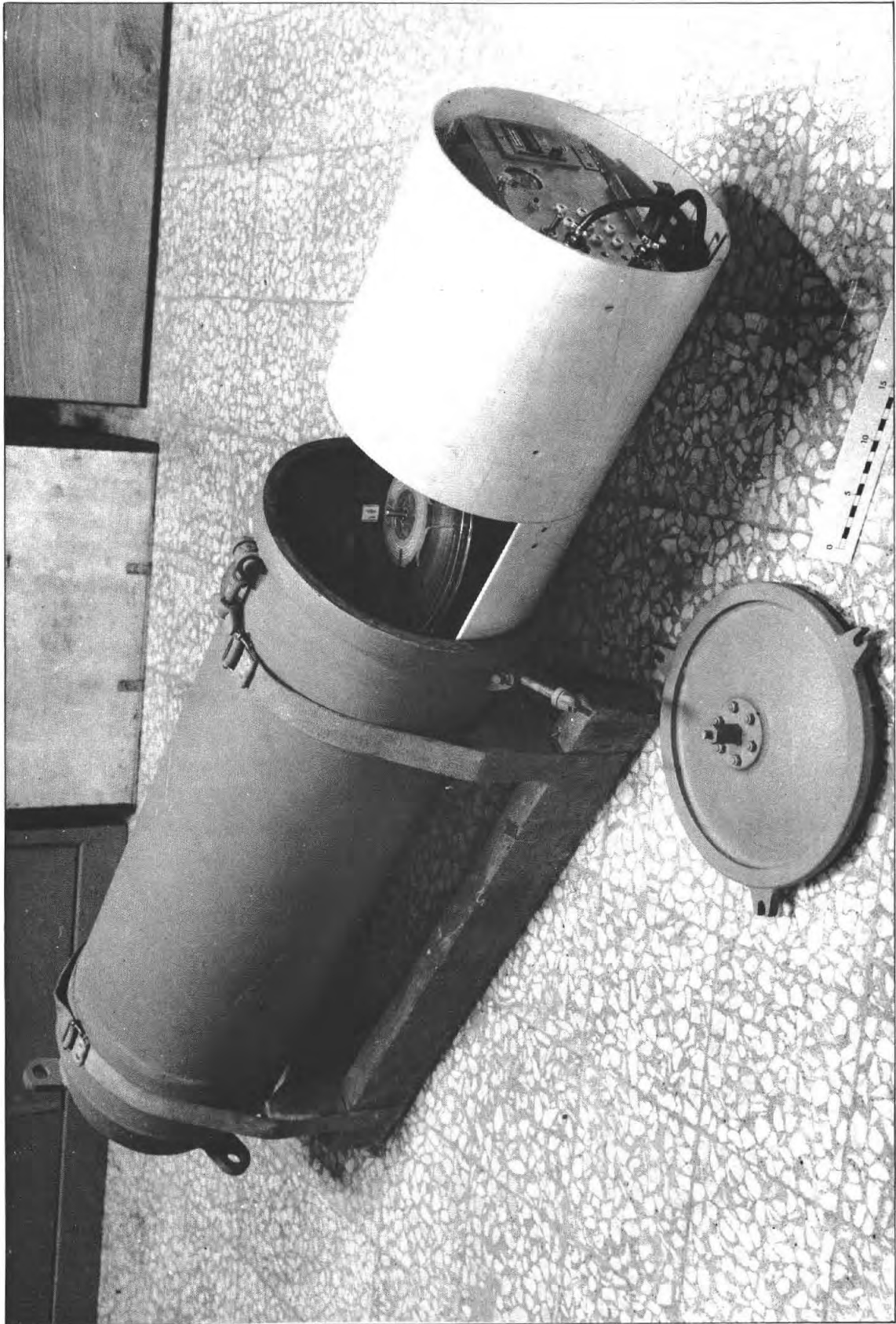
Savonius Rotor  
Circuit

Quick Clamp-on  
Badminton Shuttlecock Vane

Circuit  
Compass Assembly

**FIG. 4 A SET OF PROBES CLAMPED ON THE CONDUCTIVE MOORING LINE  
WEIGHTS QUOTED ARE IN SEA WATER**

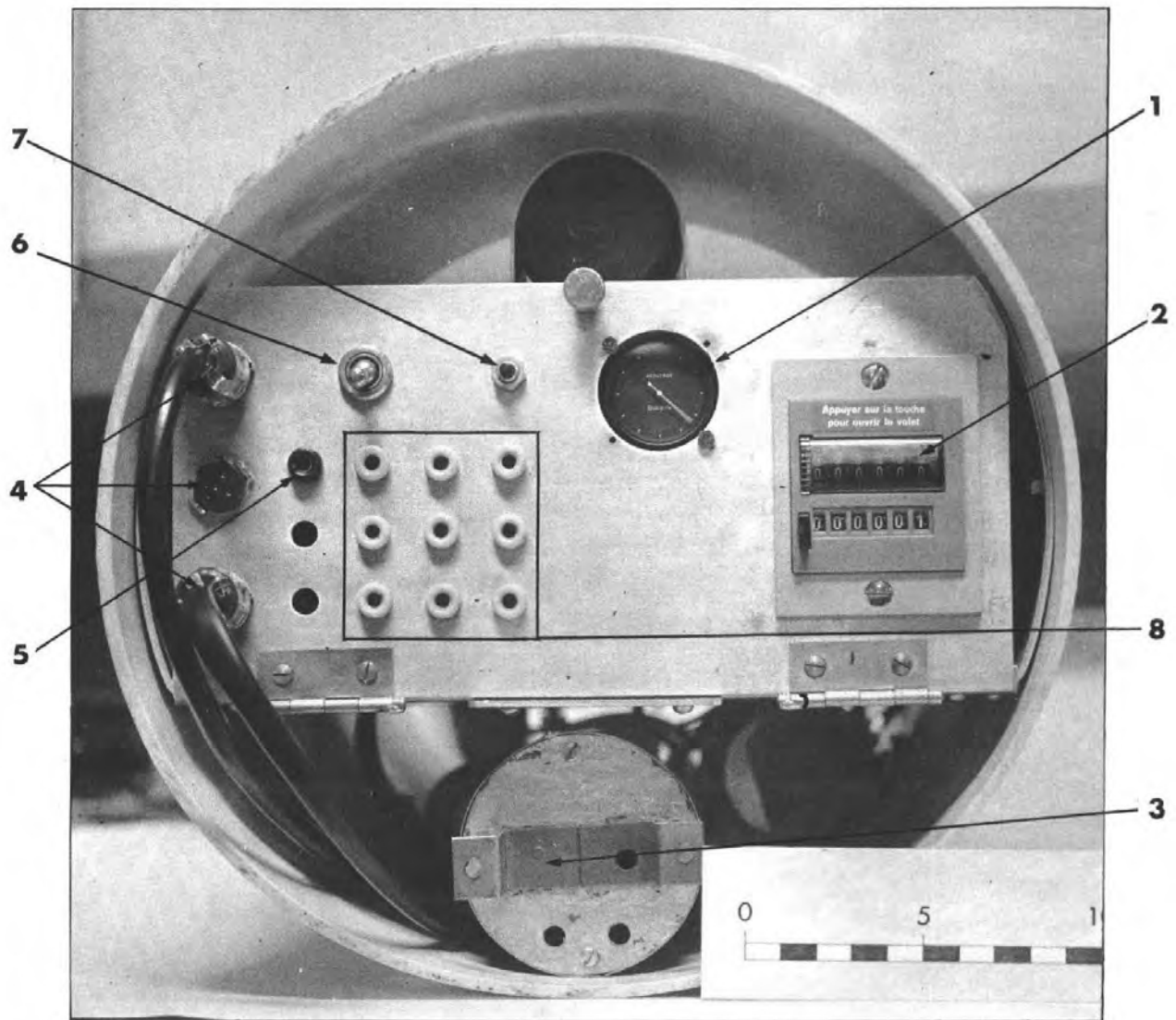




**FIG. 5 INSTRUMENT PACKAGE SLIDING INTO CONTAINER**

PART OF THE TAPE RECORDER IS SEEN THROUGH THE CENTRE OPENING AND THE PROGRAMMER IS SEEN AT THE OPEN END  
AN ARRANGEMENT FOR SIX BULKHEAD CONNECTORS CAN BE SEEN IN THE CENTRE OF THE HATCH COVER



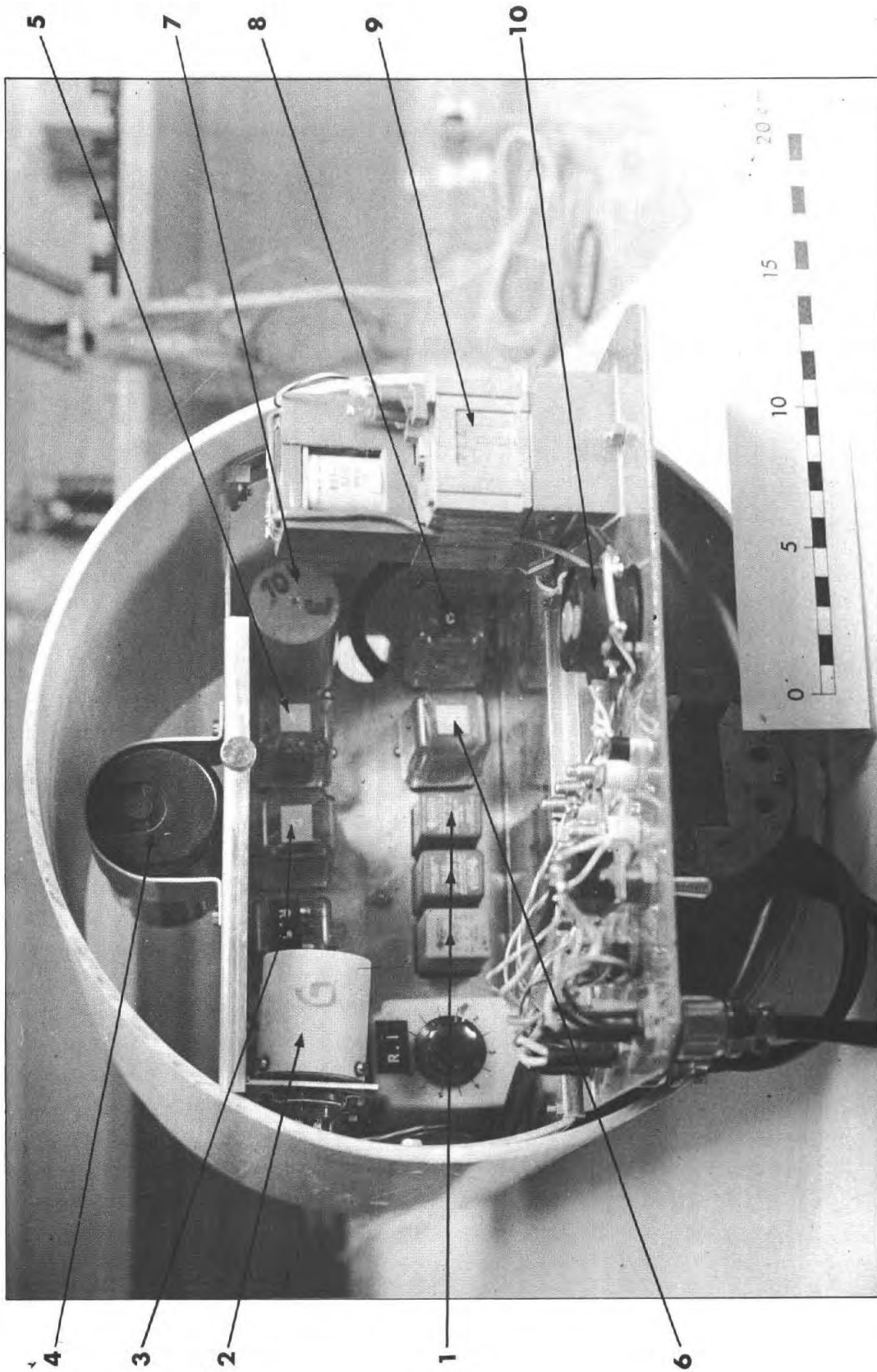


**FIG. 6a PANEL OF THE PROGRAMMER**

1. BULOVA TIMER
2. RESET COUNTER
3. RDF BEACON TRANSMITTER 27 MHz
4. POWER AND ARRAY CONNECTOR
5. GROUND TEST POINT
6. MANUAL SWITCH-ON
7. CYCLE TEST SWITCH (jumps timer)

8. NINE TEST POINTS FROM UPPER TO LOWER, LEFT TO RIGHT:
  - 1-2 CHECK PROPER PULSE CURRENT (1 mA) FOR MAGNETIC HEAD
  - 3 TESTS FREQ. OUTPUT FROM BULOVA (0.2 V PEAK TO PEAK)
  - 4-5 CHECKS CURRENT LEVEL FOR CH2 MAGNETIC HEAD
  - 6 CHECKS PULSE ARRIVALS DIRECT FROM ARRAY
  - 7 CHECKS VOLTAGE ON THE ARRAY
  - 8-9 CHECKS POWER OUTPUT FROM BATTERIES GROUPS 24V AND 12V





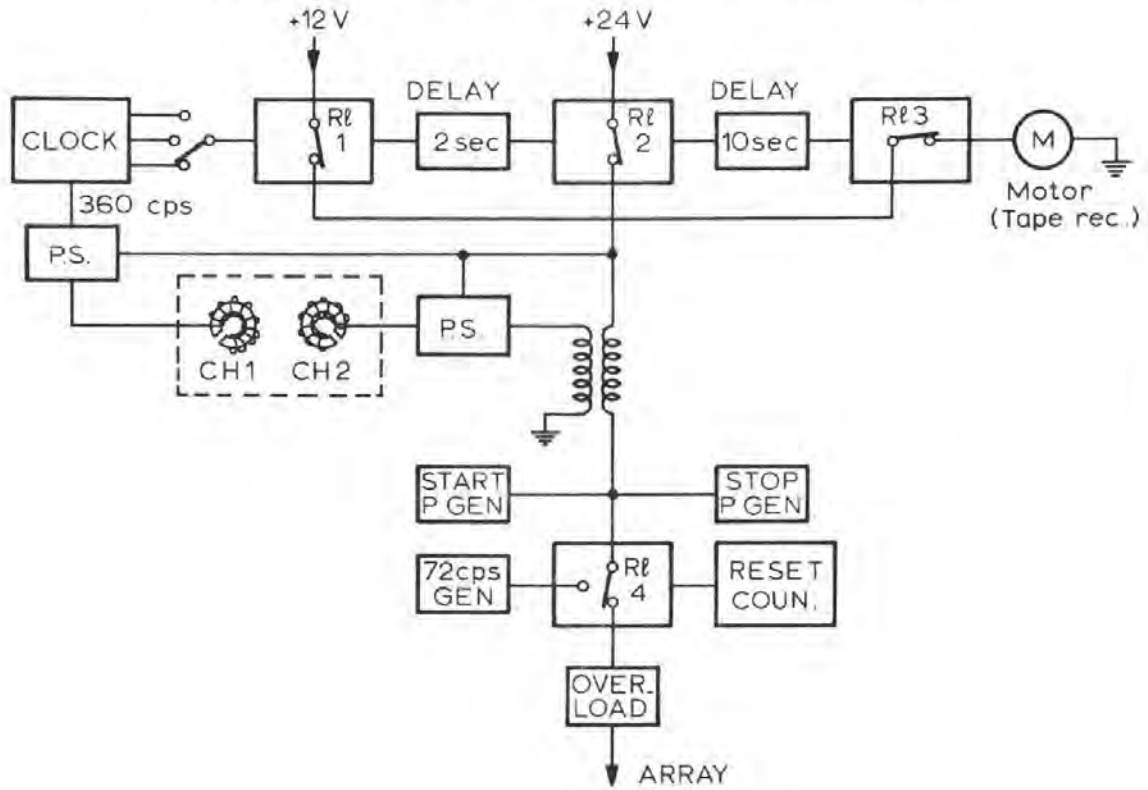
**FIG. 6b INSIDE VIEW OF THE PROGRAMMER**

- |                                |                                      |
|--------------------------------|--------------------------------------|
| 1. SET OF 4 RELAYS             | 6. PULSE SHAPER                      |
| 2. 32 ms PULSE CIRCUIT         | 7. 10 sec DELAY (end of Cycle Pulse) |
| 3. SHORT CIRCUIT CUT-OFF RELAY | 8. CLOCK FREQUENCY AMPLIFIER         |
| 4. RESET COUNTER'S CAPACITOR   | 9. RESET COUNTER                     |
| 5. CLOCK PULSE AMPLIFIER       | 10. BULOVA CLOCK                     |



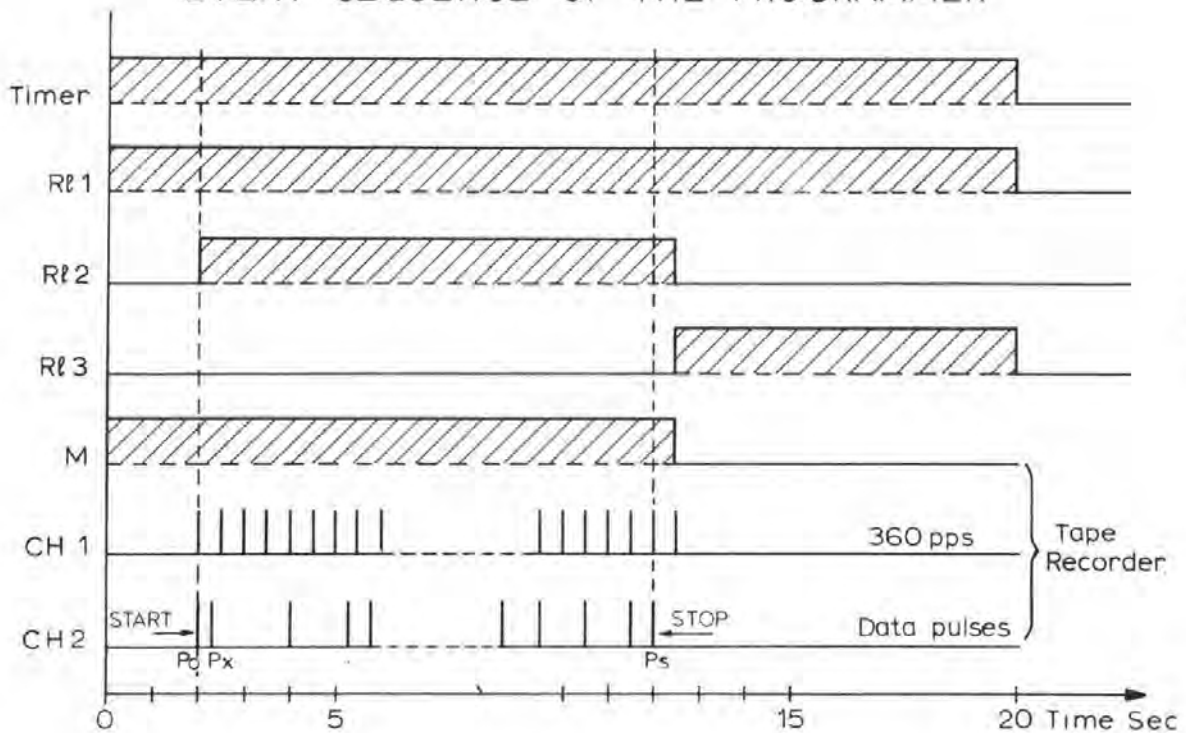


### BLOCK DIAGRAM OF THE PROGRAMMER



a)

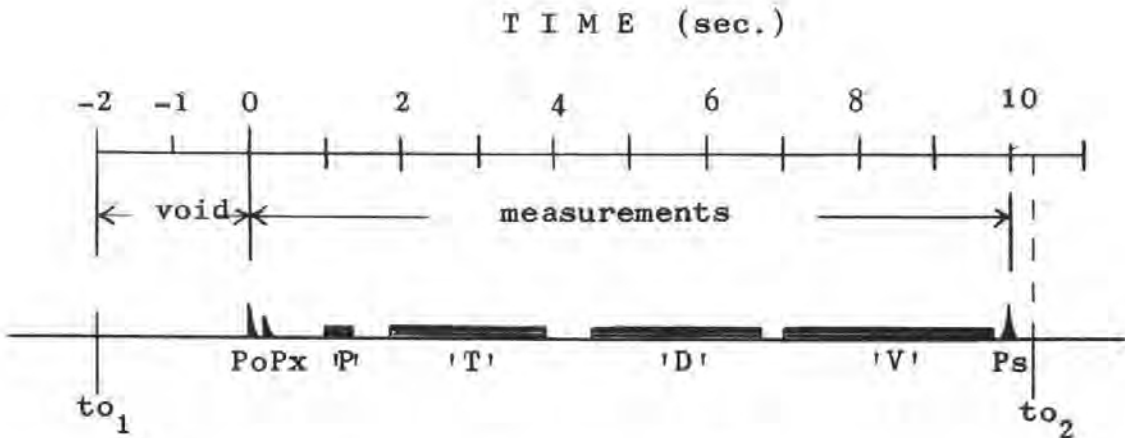
### EVENT SEQUENCE OF THE PROGRAMMER



b)

FIG. 7 THE PROGRAMMER: BLOCK DIAGRAM AND EVENT SEQUENCE

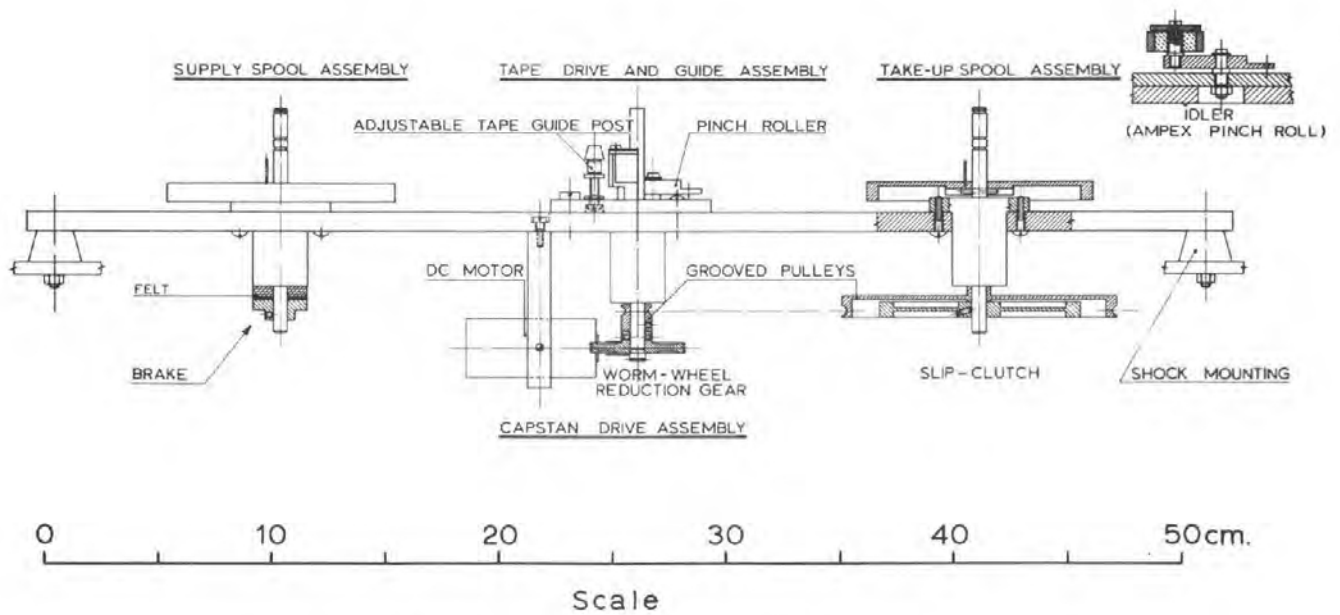




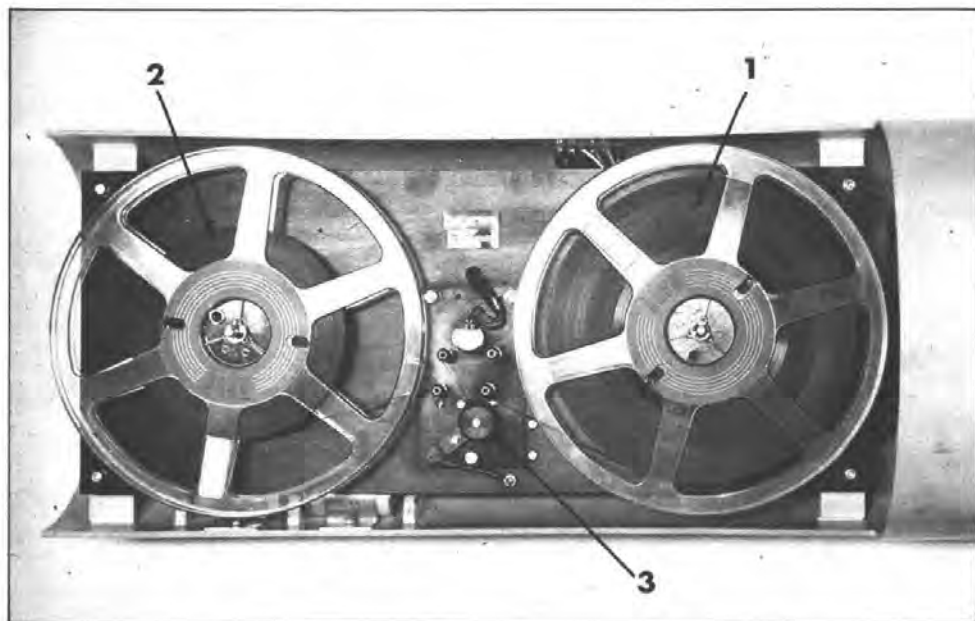
Two seconds of empty tape, from  $t_{0_1}$  to  $P_0$ , are needed for play-back reasons. During this time the recorder reaches steady state. Each cycle of measurements is started at 0 sec, with  $P_0$  followed by a test pulse,  $P_x$ , 32 ms later. 'P'(pressure), 'T'(temperature), 'D'(direction) and 'V'(velocity) follow in groups of discrete pulses. The staggered circuits of each group of probes send their individual return pulse in sequence from the shallowest to the deepest on the array.  $P_s$  establishes the end of the cycle and of the 10 sec. This pulse is also used for calibration purposes, the next cycle follows with a minimum of tape waste at  $t_{0_2}$ .

FIG. 8 PULSE RECORDING SEQUENCE ON TAPE RECORDER DURING ONE CYCLE MEASUREMENT





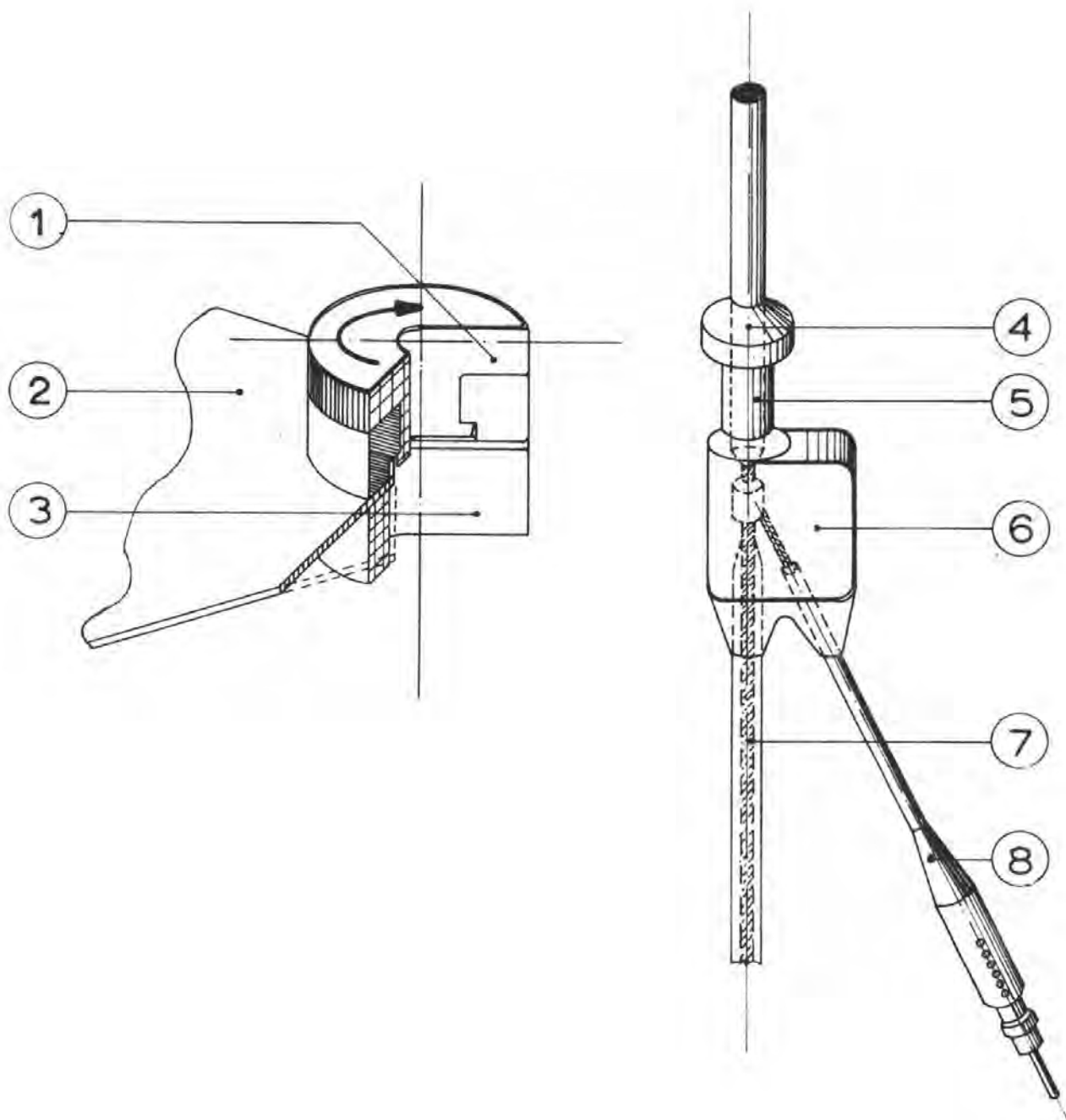
**FIG. 9a THE MAGNETIC TAPE RECORDER**



**FIG. 9b THE MAGNETIC TAPE RECORDER**

1. SUPPLY SPOOL
2. TAKE-UP SPOOL
3. TAPE LOOP DRIVE, RECTIFIED PLATE





**FIG. 10 CABLE OUTLET AND INSTRUMENT CLAMP-ON DEVICE**

A SINGLE MOULDING PROVIDES AN ELECTRICAL OUTLET (8) AND A MECHANICAL SUPPORT (4, 5, & 6) THAT PREVENTS THE PROBES FROM SLIDING OR TURNING ON THE CABLE (7). THE CLAMP (1) ATTACHED TO THE CURRENT METERS (2) LOCKS ON THE CABLE IN THE SAME WAY AS A HYDROGRAPHIC CABLE MESSENGER.





DOUBLE TERMINAL JOINT

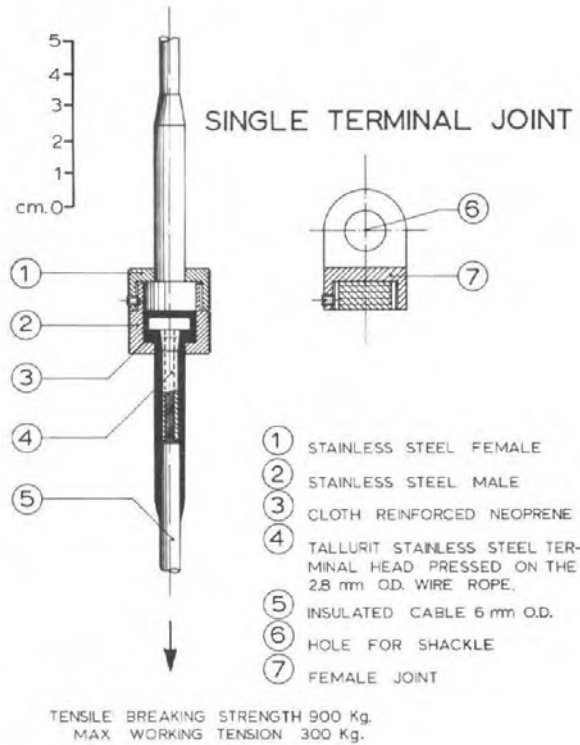


FIG. 11a CONDUCTIVE JOINTS FOR CONNECTING SECTIONS OF INSULATED CABLE

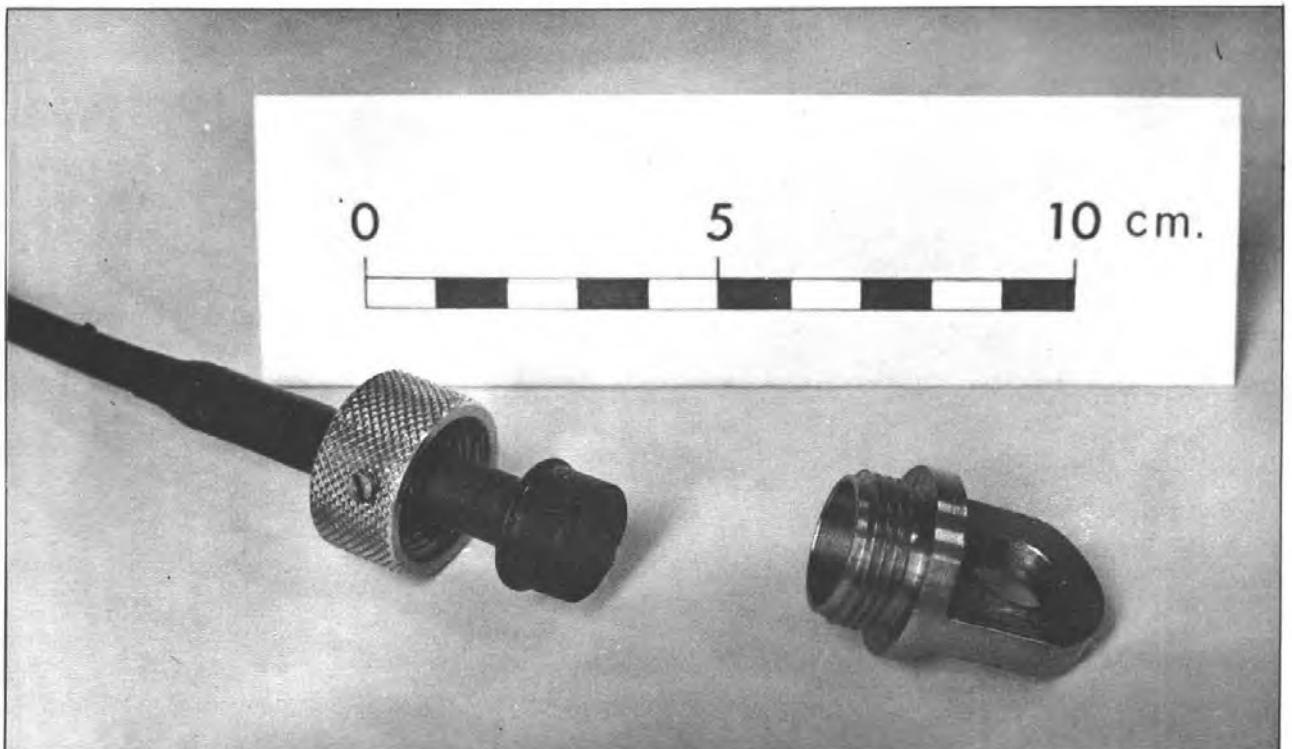
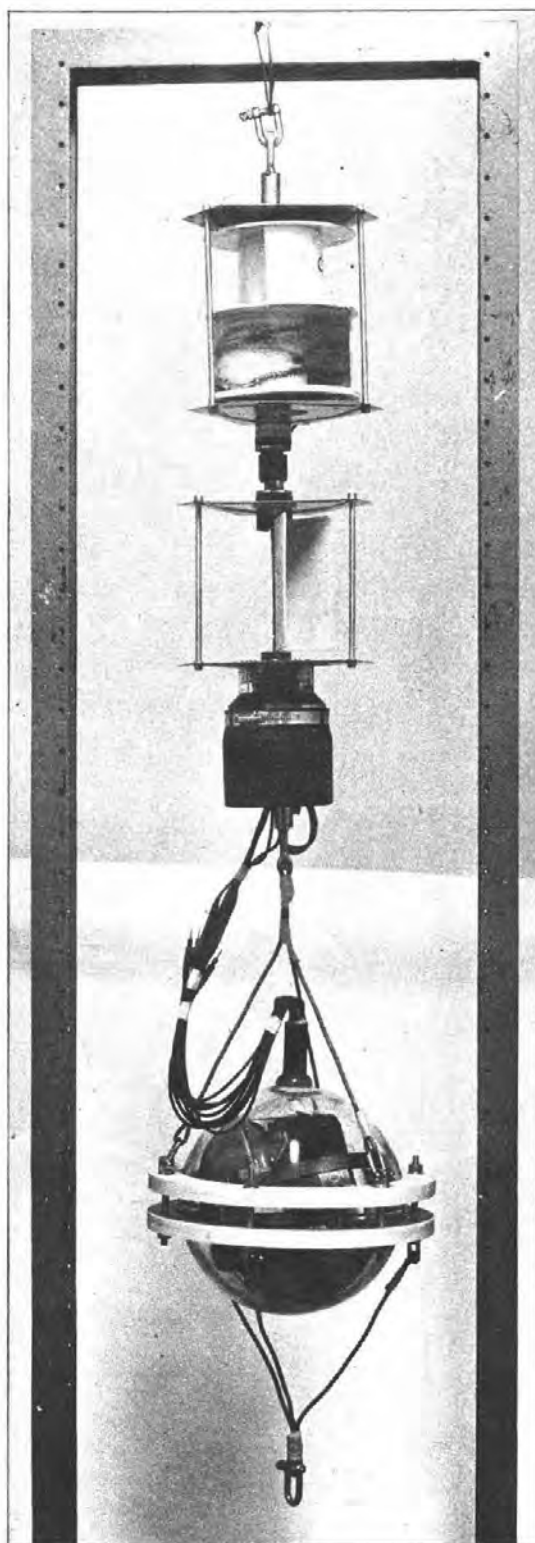


FIG. 11b CONDUCTIVE JOINTS FOR CONNECTING SECTIONS OF INSULATED CABLE

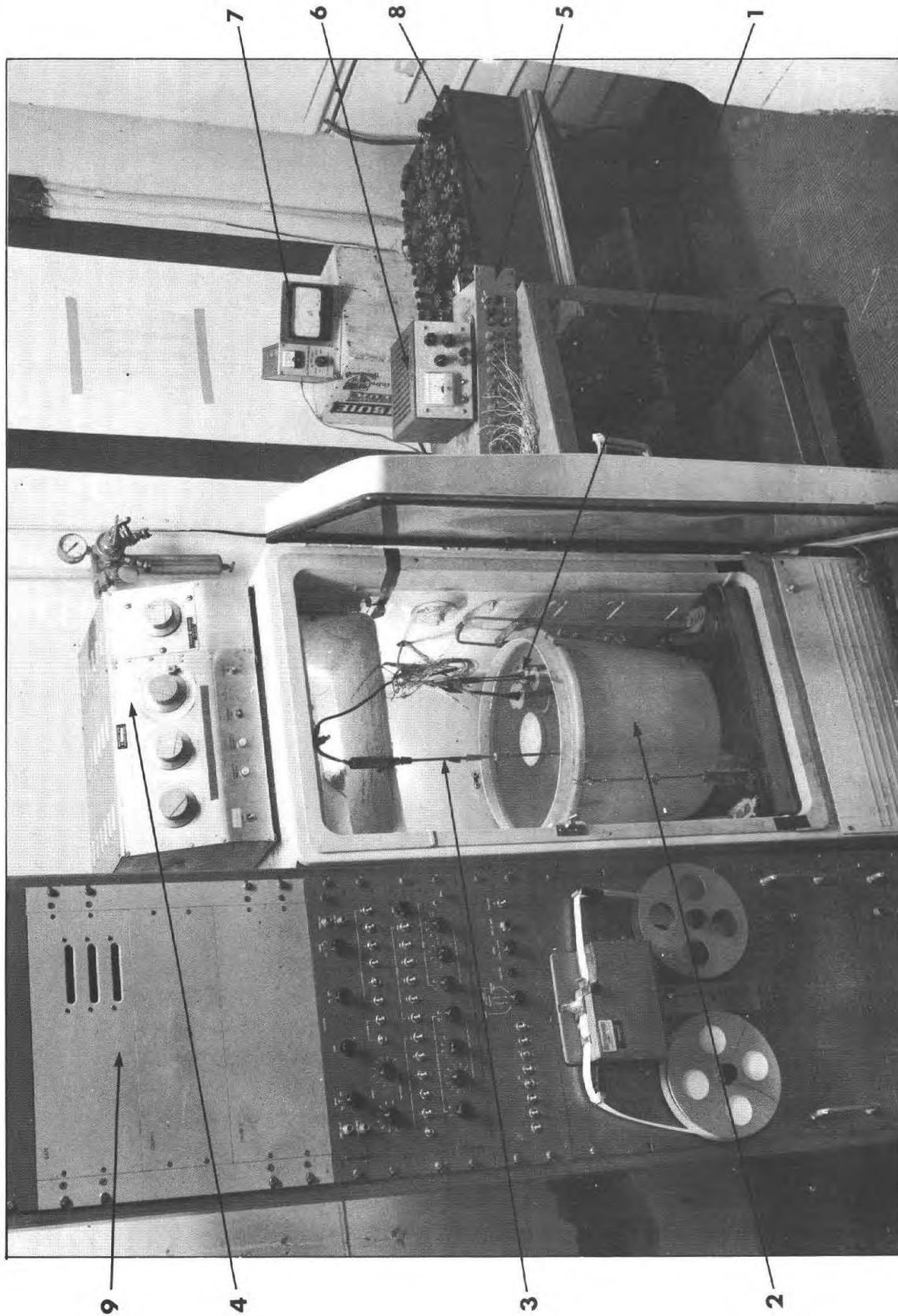




**FIG. 12 PHOTOGRAPH OF THE ARRAY 2 CURRENT METER**

FROM TOP TO BOTTOM ARE THE SAVONIUS ROTOR VELOCITY PROBE (0.55 kg.), THE DIRECTION PROBE AND ITS MAGNETIC-COMPASS/POTENTIOMETER ASSEMBLY (0.8 kg.), AND THE GLASS SPHERE CONTAINING THE POWER SUPPLY AND RECORDER UNIT (the whole being neutrally buoyant),



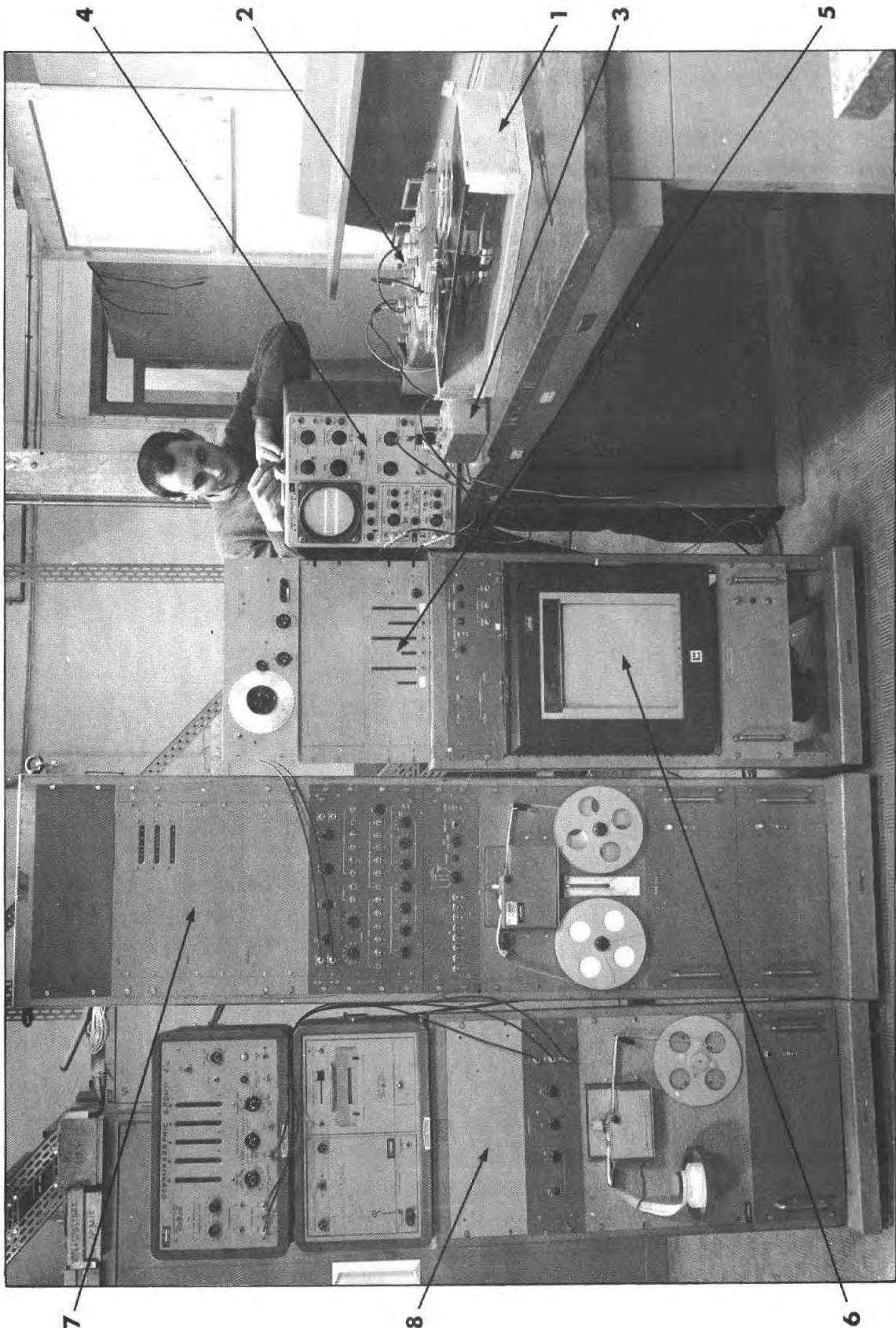


**FIG. 13 TEMPERATURE CALIBRATION ASSEMBLY**  
 1. THERMOMETERS  
 2. ISOTHERM. BATH.  
 3. ROSEMOUNT - PLATINUM THERM. REFERENCE

4. FISHER ISOTHERM - TEMPERATURE CONTROL  
 5. TIMER-MATCHING UNIT FOR PUNCHER  
 6. POWER SUPPLY OF THERMOMETERS

7. BRIDGE'S GALVANOMETER  
 8. MULLER BRIDGE  
 9. PUNCHER - RECORDER





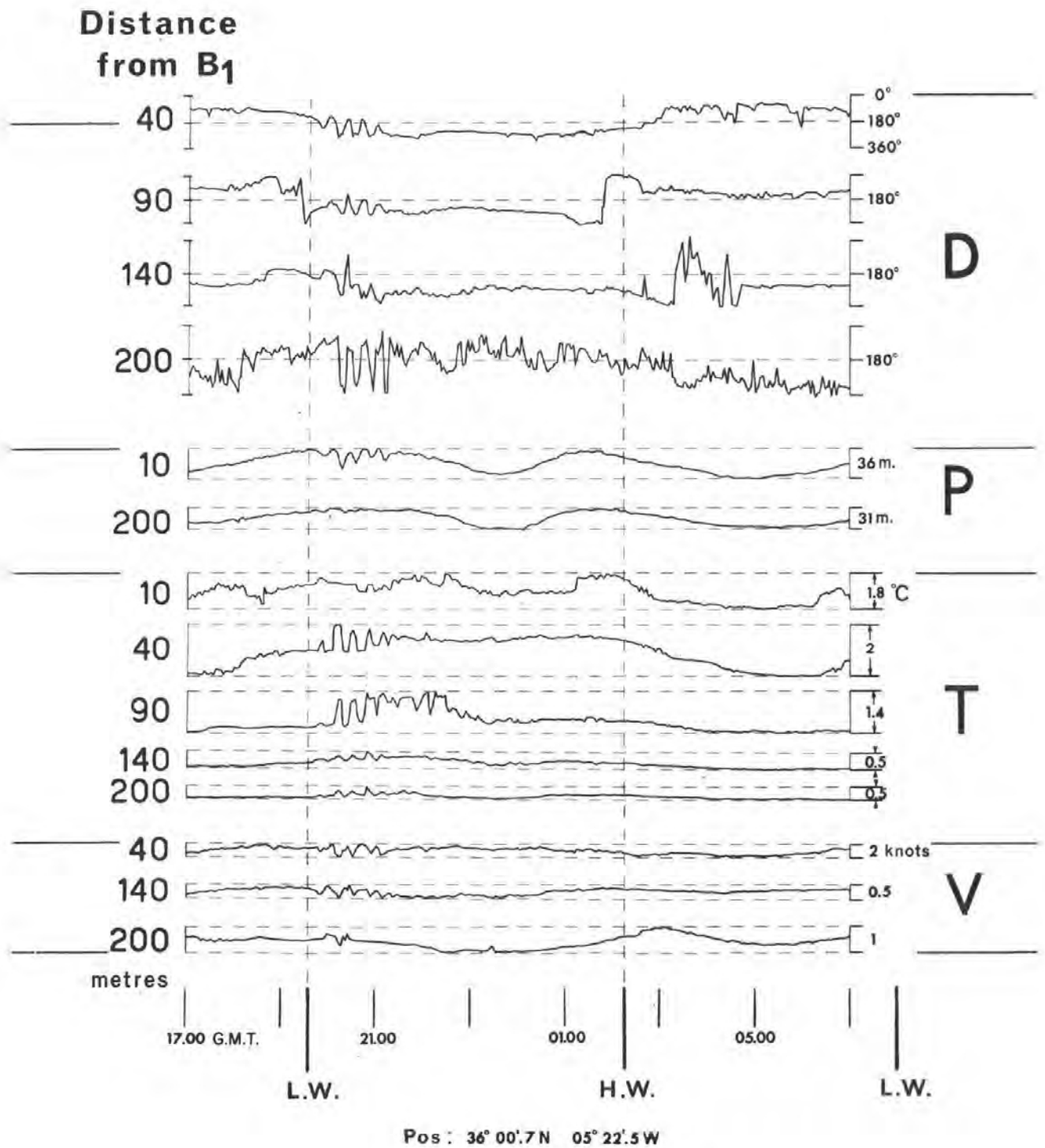
**FIG. 14 DATA CONVERSION ASSEMBLY**

- 1. TAPE RECORDER
- 2. MILLIVAC AMPLIFIER FILTERS
- 3. PULSE SHAPER
- 4. OSCILLOSCOPE; DATA PULSES AND REFERENCE
- 5. FREQUENCY DISPLAY FOR PLAY-BACK CONTROL

- 6. CYCLE COUNTER
- 7. L.N. ANALOGUE RECORDER AND DRIVER
- 8. DIGITAL RECORDER UNIT-PUNCH TAPE
- 9. PUNCH TAPE READER AND COUNTER-PRINTER UNIT

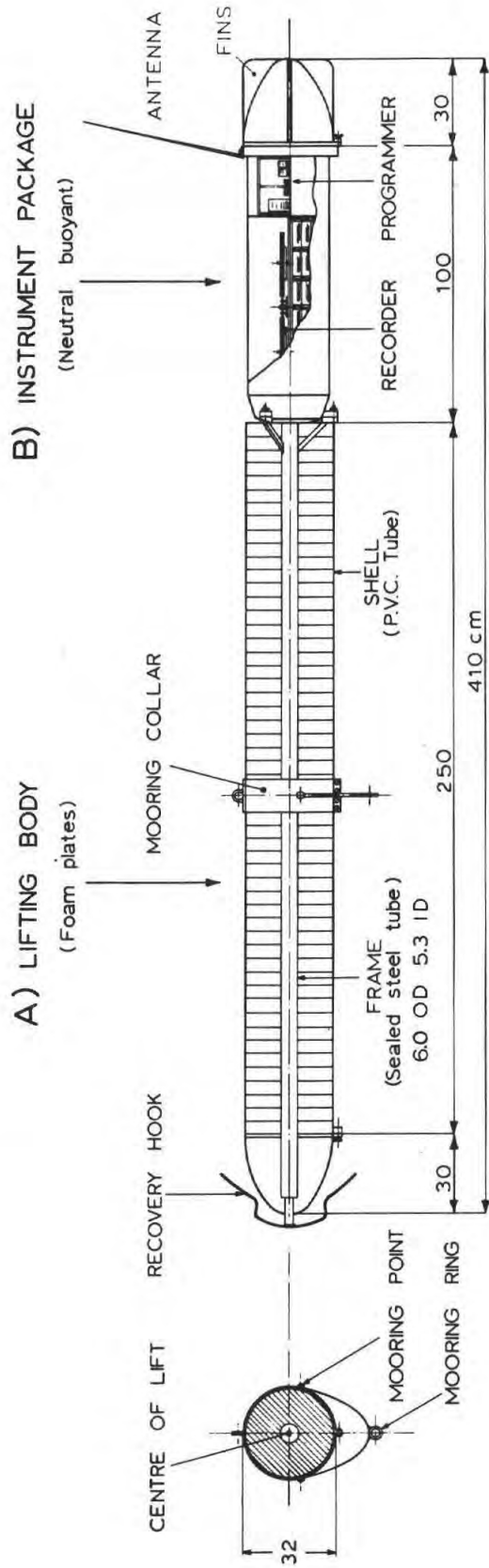






**FIG. 15 EXAMPLE OF PLOTTED DATA FROM ARRAY L**





CROSS SECTION

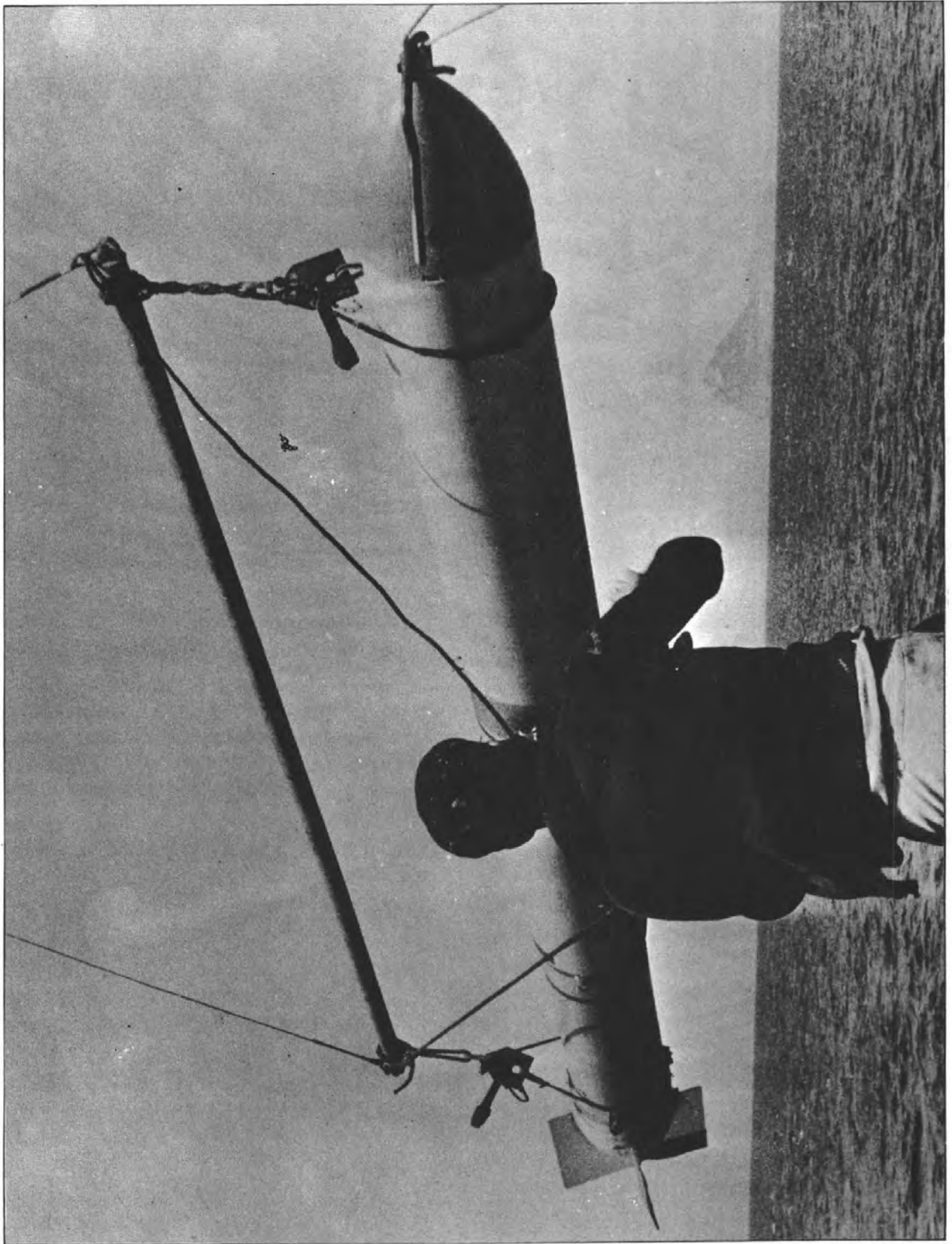
SIDE VIEW

OPERATING PRESSURE 30 Kg/cm<sup>2</sup> (OR 150 metres DEPTH)

	WEIGHT IN AIR (Kg)	NET LIFT IN WATER (Kg)
A) NET	114	130
B) EQUIPPED	63	0
TOTAL	177	130

**FIG. 16a SUBSURFACE BUOY, B1**  
THE NUMBER OF FOAM PLATES (KLEGENCELL) CAN BE VARIED TO GIVE THE REQUIRED LIFT NET LIFT IS ABOUT 55 kg PER metre LENGTH





**FIG. 16b** SUBSURFACE BUOY, BI, BEING LAUNCHED



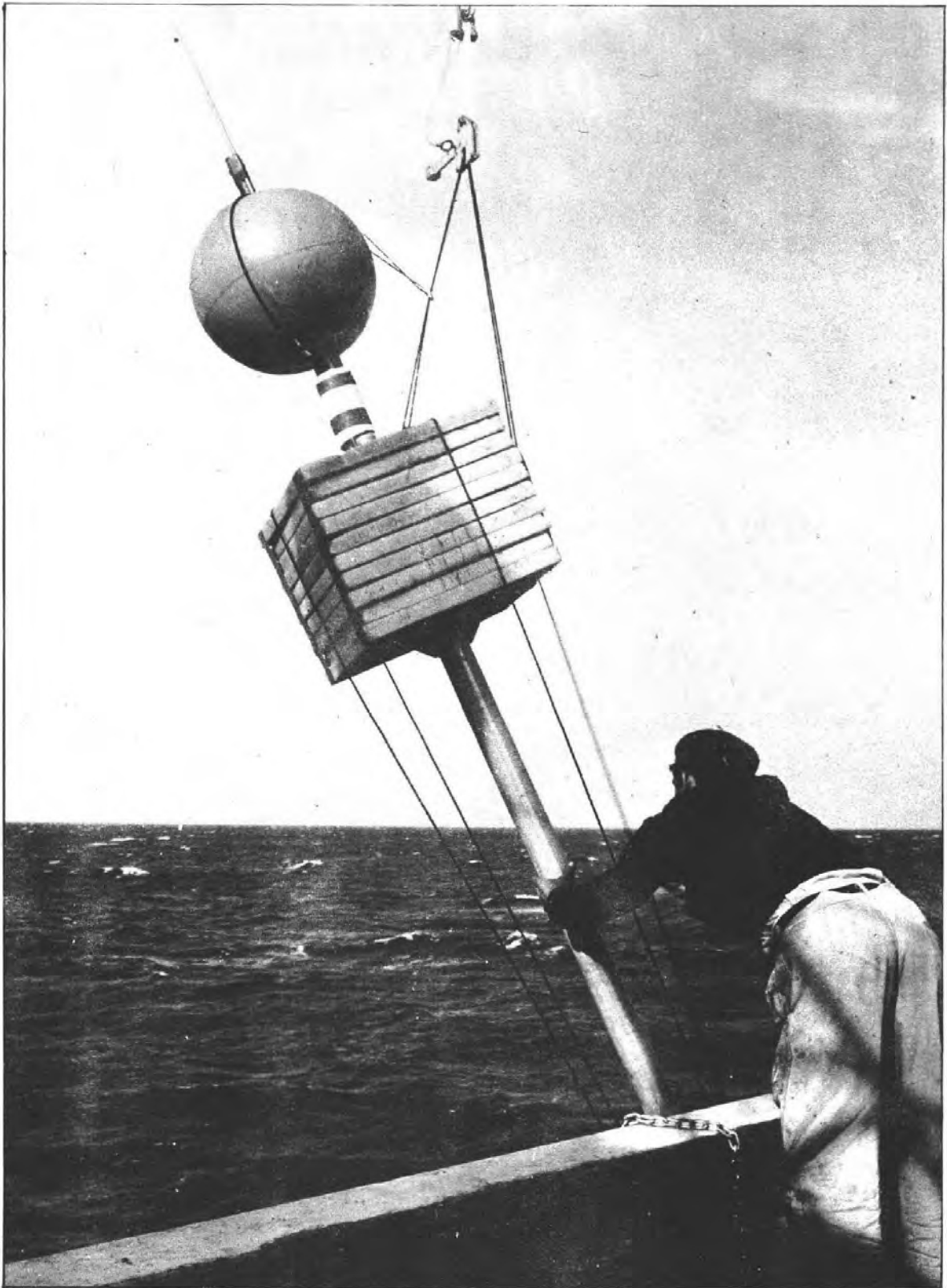


**FIG. 17 LOWER BUOY, B2**

AS THIS OPERATES IN DEEPER WATER THAN B1 IT USES THE CHEAPER, SQUARE PLATES OF KLEGENCELL AND IS MORE SIMPLY FAIRED WITH PLASTIC SHEETS. THE BEACON ANTENNA IS SEEN ON THE NOSE.



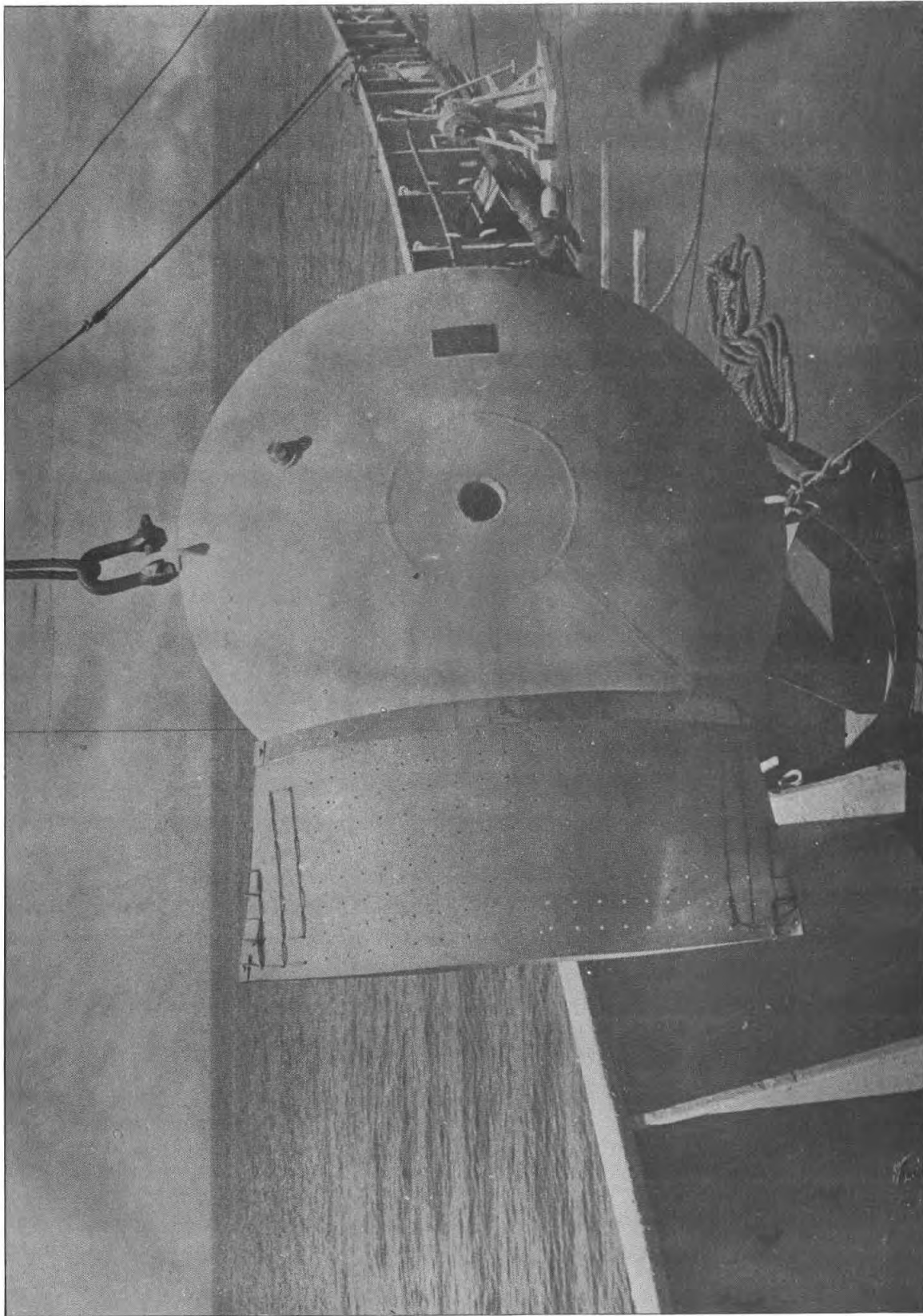




**FIG. 18a OTHER TYPE OF BUOY USED IN THE PROJECT**

A SPAR BUOY FOR DEEP SUBMERGENCE WHERE CURRENTS ARE NEGLIGIBLE. THE SPAR CONTAINS A BEACON TRANSMITTER. KLEGENCELL PLATES GIVE LIFT. THE ORANGE RUBBER BALLOON COLLAPSES AT DEPTH BUT AIDS IDENTIFICATION ON THE SURFACE

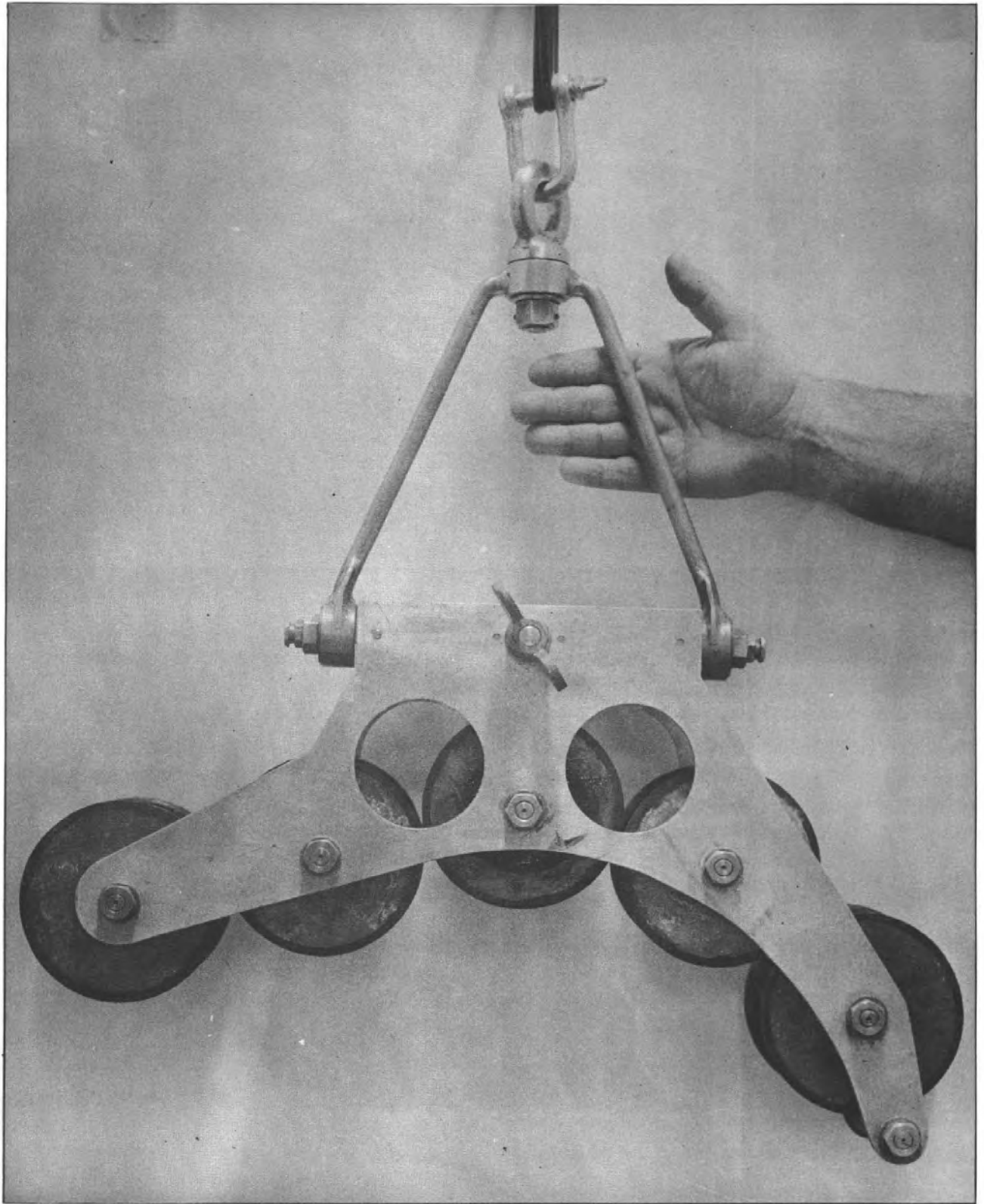




**FIG. 18b OTHER TYPE OF BUOY USED IN THE PROJECT**

LENTICULAR BUOY FOR DEEP SUBMERGENCE WHERE CURRENTS OCCUR. THE ORIENTING TAIL IS OF FIBREGLASS. THE STEEL BUOY CAN BE PRESSURIZED THROUGH THE VALVE IN ITS SIDE TO MAKE IT USABLE DOWN TO 600 m. ITS TOTAL WEIGHT IN AIR IS 80 kg AND ITS NET LIFT IS 100 kg





**FIG. 19 ROLLER BLOCK FOR PASSING ARRAY I**



## APPENDIX 1

### SUMMARY OF CERTAIN FUNDAMENTALS

#### 1.1 Present Capabilities of the System

Data storage capacity max. 16 000 cycles or 400 000 individual data.

Interrogation rate max. 30 sec.

Range and sensitivities:

*T Temperature	10°C; $\pm 0.01^\circ\text{C}$
D Direction	0°-360°; $\pm 5^\circ$
V Velocity	0.05 - 4.0 kn; 5% of the value
P Depth	0-100 m and 0-500 m; $\pm 0.5\%$ full scale
t time	1 year battery life; 1 part in $8.6 \times 10^4$

\*The range is taken in the best section of the calibration curve. Staggering technique places each thermometer in its right temperature range (10-20, 15-25°C. etc.)

#### 1.2 Weight in Water of Components:

T thermometer, ea.	0.06 kg
V	0.55 kg
D	0.80 kg
P	0.20 kg
Swivels	0.32 kg
6-mm insulated wire,	5.0 kg per 100 m (see Appendix 3)
3.2-mm bare wire rope,	6.0 kg per 100 m

1.3 Estimated Costs - excluding labour

<u>Durable items:</u>	<u>\$ U.S</u>
Lifting buoy B <sub>1</sub> 130 kg net lift	800
Lifting buoy B <sub>2</sub> 150 kg net lift	400
Instrument container and tail	200
Programmer (Bulova: \$285)	550
Tape Recorder	350
Acoustic Releaser (sea unit)	150
Time Releaser	30
Squib Container	20
RDF Beacon Transmitter	250
	<hr/>
	2,750

Probes complete with circuits:

T 37 ea x 10 in one array	370
V 53 ea x 5 in one array	265
D 97 ea x 5 in one array	530
P 350 ea x 2 in one array	700
	<hr/>
22 in one array	1,865



Operating Cost - expendable components:

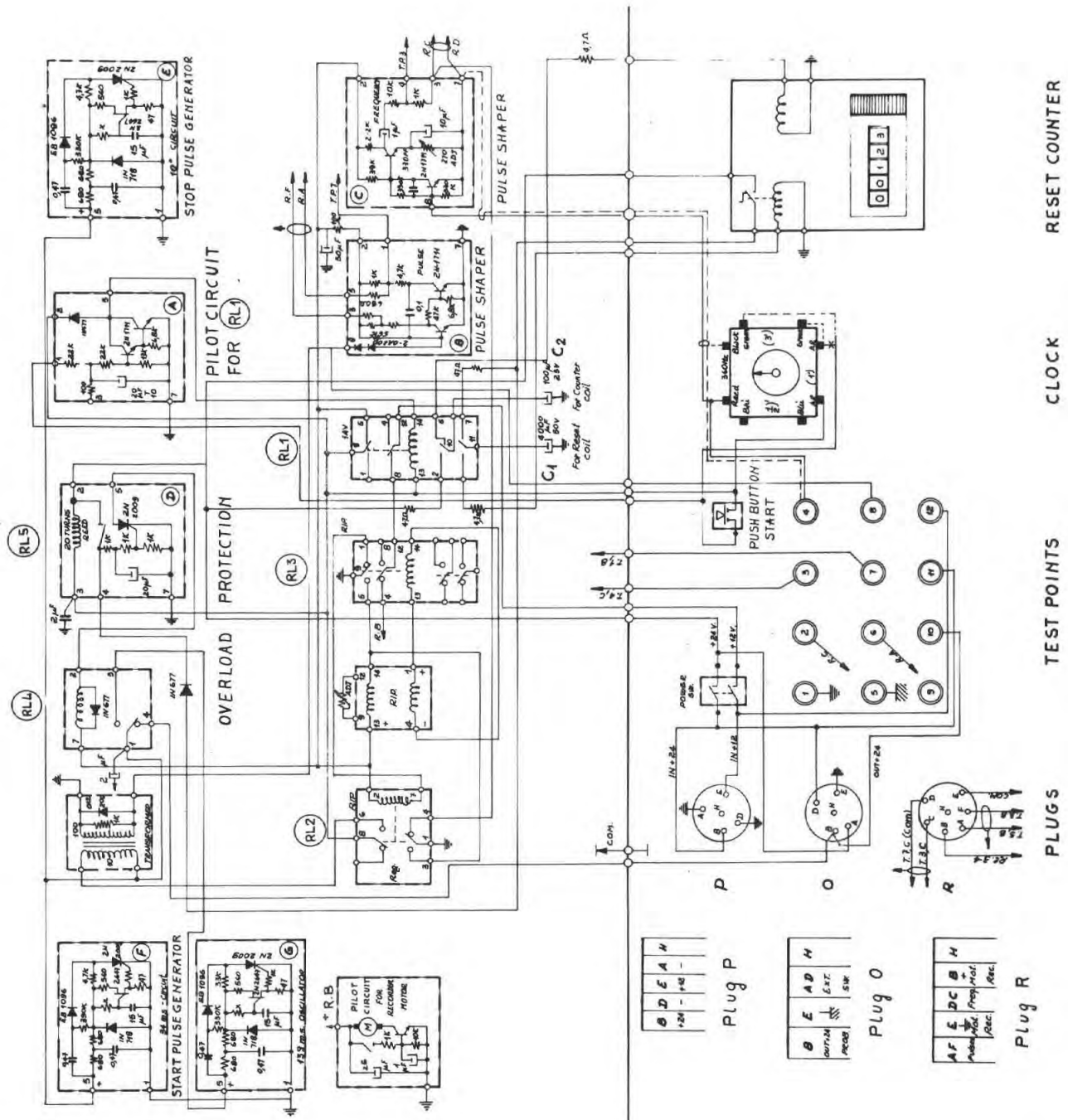
250 m neoprene insulated cable section with terminals and outlets	100
800 m steel wire rope galvanized (10 cents per metre)	80
300 kg scrap iron chain (about 13 cents per kg)	40
15 kg anchor and small chain	25
2 squibs	18
Mercury batteries (1 month operation)	110
	<hr/>
	373

NOTE: Wires and cables are reusable for other purposes, as are parachute drogues, etc.) Parachutes from Army Disposal cost \$1 each.



# APPENDIX 2

## DETAILED CIRCUIT DIAGRAM OF THE PROGRAMMER



A)

B)



### APPENDIX 3

#### Precision Miniature Timer for the Programmer

Make : Bulova Cycle Timer Model 11-15

Accutron mechanism based on vibrating timing fork

Weight: 40 gm

Size : 1 x 1 x 0.5 in.

Power Supply : Microcell battery for 1 year operation incorporated.

Accuracy : about 1 sec/day or 1 part in 86,000 in a temperature range of -3 to +40°C

Timing Fork Vibrating Frequency : 360 Hz

Timing Outputs : 1, 2, and 3 minutes switch for 20 sec. closure

Dial : 1 in. diameter, with needle for visual time control.

Time resetting device

Price : U.S. \$200 to \$330, depending on the accessories requested, which cover a variety of applications.



## APPENDIX 4

### SPECIFICATIONS OF THE ELECTRICALLY INSULATED WIRE ROPE PRESENTLY USED

1. Wire rope formation: 37 wires of 0.4 mm OD;  
1 + 6 (to right) + 12 (to left) + 18 (to right)  
total OD 2.8 mm.
2. Steel strength:  $220 \text{ kg/mm}^2$
3. Breaking tensile strength: 900 kg
4. Maximum working load: 300 kg
5. Electrical insulation: neoprene 1.5 mm thick  $\pm 0.1 \text{ mm}$
6. Final diameter  $5.8 \pm 0.1 \text{ mm}$
7. Weight in water: 50 kg/km
8. Weight in air 83 kg/km
9. Radius of curvature about 10 cm
10. Electrical resistance  $40\Omega/\text{km}$
11. Terminals of special design
12. Electrical outlets of special design
13. Price per metre about 20 cents
14. Manufactured by Formara, Torino, Italy.





## APPENDIX 5

### MOORING LINE MOTION

The buoy system described is a subsurface system, the upper buoy of which is generally placed below the ship's draught, reasonably decoupled from the action of surface waves and wind but subject to the hydrodynamic forces of ocean currents to which the system complies.

The 'soft' mooring has practical advantages over more rigid systems as long as the compliance is relatively small and measurable.

The problem is to identify observational depths in time, avoiding the expensive system featuring a depth gauge for each instrument. By considering the "catenary" to be made of two or three linear sections between three or four depth gauges, it appears possible to compute with sufficient accuracy the depth of each instrument along the line in time. Two gauges are sufficient however if the current does not exceed 1 kn.

A theoretical study\* was made to determine the factors that are most important in influencing the depth loss (dip) of the buoys and instruments on the cable. In the model the system was presumed to be moored in a depth of 870 m (corresponding to actual usage in the Strait of Gibraltar), to have a 250 m array between the two buoys, and to be exposed to an extreme velocity profile of a constant 4 kn in the upper 50 m, a constant 0.5 kn in the lower 570 m, and a proportional decrease in eight intervening steps.

---

\* made by B.Schipmølder and reported in an unpublished paper.

Table 1.1 shows how much the depth loss (dip) of the upper buoy is reduced by adjusting the various factors. The adjustments that revealed the greater reductions in dip are indicated by stars.

TABLE 1.1

	<u>Depth Loss</u> <u>(Dip)</u>	<u>Percentage</u>
<u>Starting Conditions</u>	<u>87 m</u>	<u>100</u>
<u>Adjustments</u>		
*Buoys' lift increased by 20%	76	-12*
Weight of cables reduced by 20%	86	- 1
*Diameter of cables reduced by 20%	77	-11*
Drag coefficient of buoys reduced by 90%	80	- 8
*Drag coefficient of upper cable reduced by 75%	44	-50*
Drag coefficient of lower cable reduced by 75%	86	- 1

From the results shown in Table 1.1 it appears clear that the diameter of the cable should be kept to a minimum, and the buoys' lift kept at a maximum, (which implies increasing the cable tensile strength). The most promising advantage, however, would be obtained by fairing the cable where it is exposed to currents exceeding 1 kn. By these three methods the angle of the catenary to the vertical can be kept at values that (a) minimize errors due to tilt of current meters, (b) minimize the horizontal displacements due to rotary currents, and (c) minimize the vertical displacements, all of which, in most cases, are caused by currents having a tidal or inertia period. Figure 5.1 shows the hydrodynamic drag on cable (faired and unfaired) and wire.

# Hydrodynamic drag on cable and wire

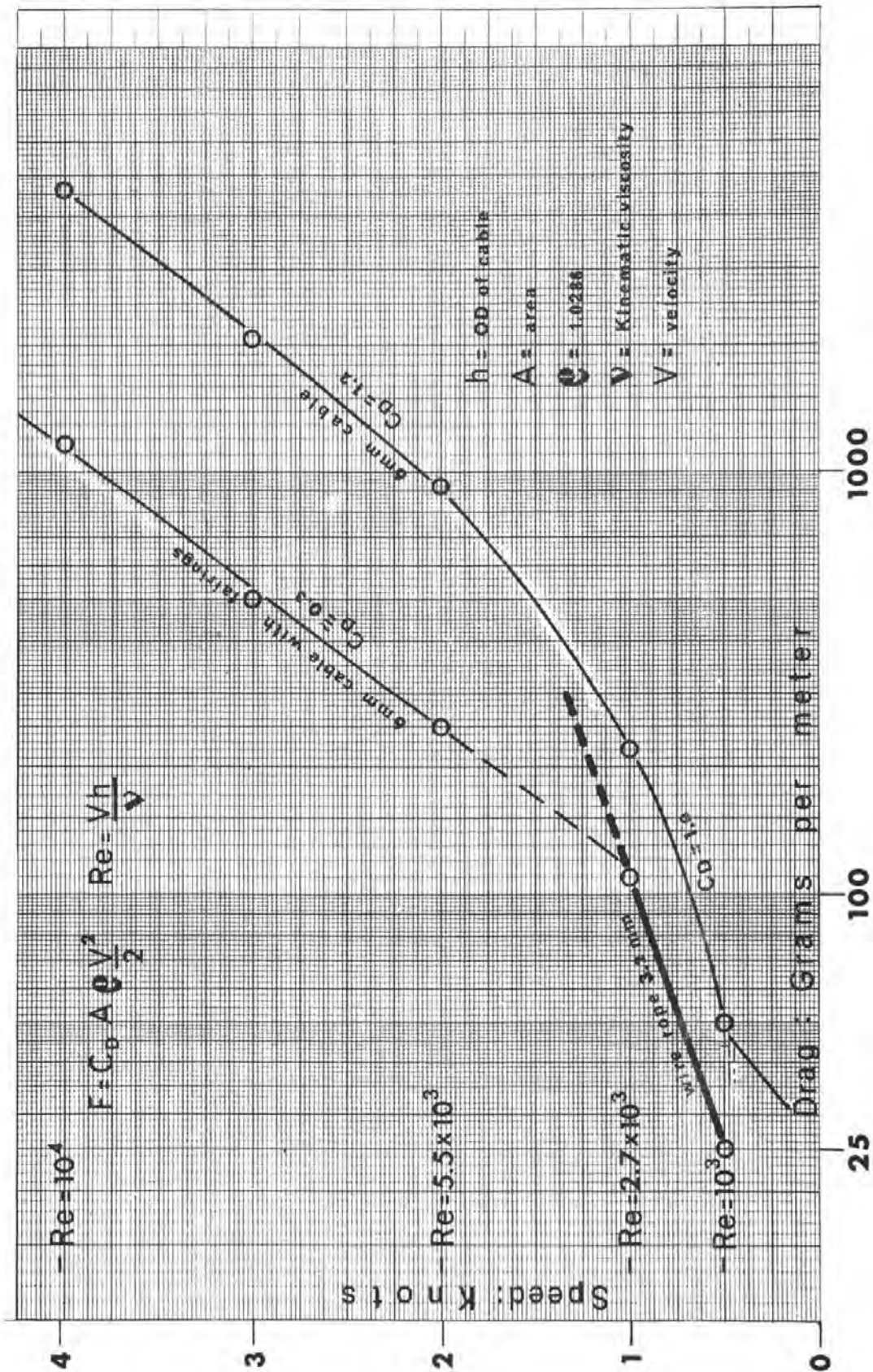


FIG. 5.1



## APPENDIX 6

### CABLE VIBRATIONS AND TORQUE

#### 1. General

Owing to its variable configuration and its unevenly distributed modes, the cable of Array 1, when subjected to tension of the lifting buoy B<sub>1</sub> and to the hydrodynamic forces of the currents, will vibrate in variable and complicated modes that are difficult to determine either theoretically or empirically.

An attempt was made to predict an order of magnitude of the vibration frequencies by using available formulas and to verify them by an empirical method. The information would be useful to provide methods of eliminating cable failures by fatigue, and in particular to prevent the cable from getting into its resonant frequency.

#### 2. Natural Transverse Vibration

The problem of determining the natural transverse vibration of the upper cable (Array 1) in water is very difficult, especially in the varying conditions. Assuming that the damping effect of the water is not great, Olson's expression (Ref. 6) was used. This defines the fundamental frequency of transverse vibrations of a string in air as

$$f = \frac{1}{2L} \sqrt{\frac{T}{m}} \quad (\text{Eq. 6.1})$$

where  $T$  is the tension in dynes ( $\text{kg} \times 981 \times 10^3$ )

$m$  is the mass of the cable per unit length in  $\text{gm/cm}$

$L$  is the length of the string between nodes in  $\text{cm}$

In our cable system:

$$T @ 120 \text{ kg} = 120 \times 981 \times 10^3 = 1.177 \times 10^8 \text{ dynes}$$

$$m = \frac{0.7}{9.80} = 7.14 \times 10^{-3} \text{ gm/cm}$$

$$L = 100 \text{ m} = 1 \times 10^4 \text{ cm between nodes (cable terminals).}$$

Equation 6.1 becomes:

$$f = \frac{1}{2 \times 10^4} \sqrt{\frac{1.177 \times 10^8}{0.714 \times 10^{-2}}} = 6.4 \text{ Hz}$$

By varying  $L$  (the distance between nodes) in Eq. 6.1 the natural vibration frequency of the array cable would vary as follows:

<u>f (Hz)</u>	<u>L (m)</u>
3.2	200
6.4	100
12.8	50
64.0	10

In addition to the fundamental, other modes of vibrations may occur in other harmonics.

In principle, the position of nodes should be determined by the end points (terminals of cable sections or a probe clamped onto the cable) that has a mass equal to or greater than the mass of the cable between the nodes. The probes in our present system have the following weights in water:

Temperature Probe = 60 gm, equivalent cable length 1.4 m

Current Velocity Probe = 550 gm, equivalent cable length 13 m

Current Direction Probe = 800 gm, equivalent cable length 19 m

It can be seen that placing different probes at the uneven spacing needed for oceanographic study complicates the modes of vibrations and probably upsets the natural frequency. This effect may turn out to be more desirable than undesirable.

It is not the purpose of this work to go further into the investigation of this theory. Water-damping effects were also not taken into consideration in the natural frequency calculation, but they should not be of major importance.

### 3. Eddy-Induced Vibrations

When exposed to ocean currents the cable will behave like a flexible cylinder under transverse flow, and vortex shedding will occur on the lee of the cable, causing vibration.

The frequency of vortex shedding  $F$  is related to the diameter of the cylinder and to the velocity of the fluid, and can be predicted in our case by the expression: (Ref. 7)

$$F = \frac{SV}{h} \quad (\text{Eq. 6.2})$$

Where  $F$  = frequency (Hz)

$S$  = Strouhal number

$V$  = velocity of flow

$h$  = diameter of cable

Figure 6.1 gives the values of this frequency as functions of current speed and Strouhal numbers (which vary with Reynolds numbers) (Ref. 8).

When the vortex shedding frequency is equal to the natural vibration frequency of the cable or to its harmonics, resonance will occur. The effects could be so extreme as to cause failure of the cable or damage to some instruments in the array.

By careful study of the system these effects can probably be greatly reduced, if not avoided.

#### 4. Empirical test - Power spectrum of vibration frequencies

Vibrations of the cable were recorded using a "reversed" array, 200 m long, suspended from a boom of the research ship and tensioned by a 100 kg weight at the lower end (including the cable weight the total tension reached 120 kg). A self-recording current



meter was placed above the weight depressor to verify the speed of the water past the cable.

A hydrophone was taped to the cable, about 5 m below the surface, and its output fed to a magnetic tape recorder. The ship drifted or moved at speeds of from 0.2 to 3 kn. The recorded magnetic tape was played back on a Sintef Statistical Analogue Computer, which automatically plotted the frequency power spectrum on an X-Y recorder. The resulting power spectrum from 0 to 220 Hz is shown in Fig. 6.2. Peak powers are revealed at 1.3 Hz (0.9 to 2.2 Hz) and at 20-23 Hz. These peaks did not change from slow-moving to faster-moving ship conditions when the cable was 25° to the vertical. Vortex shedding effects on the hydrophone itself, which may have contributed to the recorded signal, were not verified.

Lower frequencies could not be recorded because of lack of proper equipment. However, on the traces of continuously-recording current meters, clamped to the lower end of a moored buoy, a persistent oscillation of the rotor and of the vane was noticed, which had a period of 1 to 3 min. The amplitude of these fluctuations was small and fell within the resolution of the instruments, at least as far as the velocity meter is concerned, when the buoy was in good operating conditions.

These frequencies may be an effect of mooring motion and should be verified by using a proper method for measuring very low frequency vibrations on the dampened cable.

## 5. Torque

With the present system used in places like the Strait of Gibraltar, severe torque action is experienced on the insulated cable of the array of instruments placed between the two submerged floats. The floats themselves orient to the variable currents and are likely to turn at random as a result of turbulent tidal currents. Cable breaks experienced in the Strait of Gibraltar were due mostly to fatigue by torque action and were less frequent when ball-bearing swivels were used. A braided cable rather than helicoidal non-twist cable would probably be more suitable when this is available on the market.

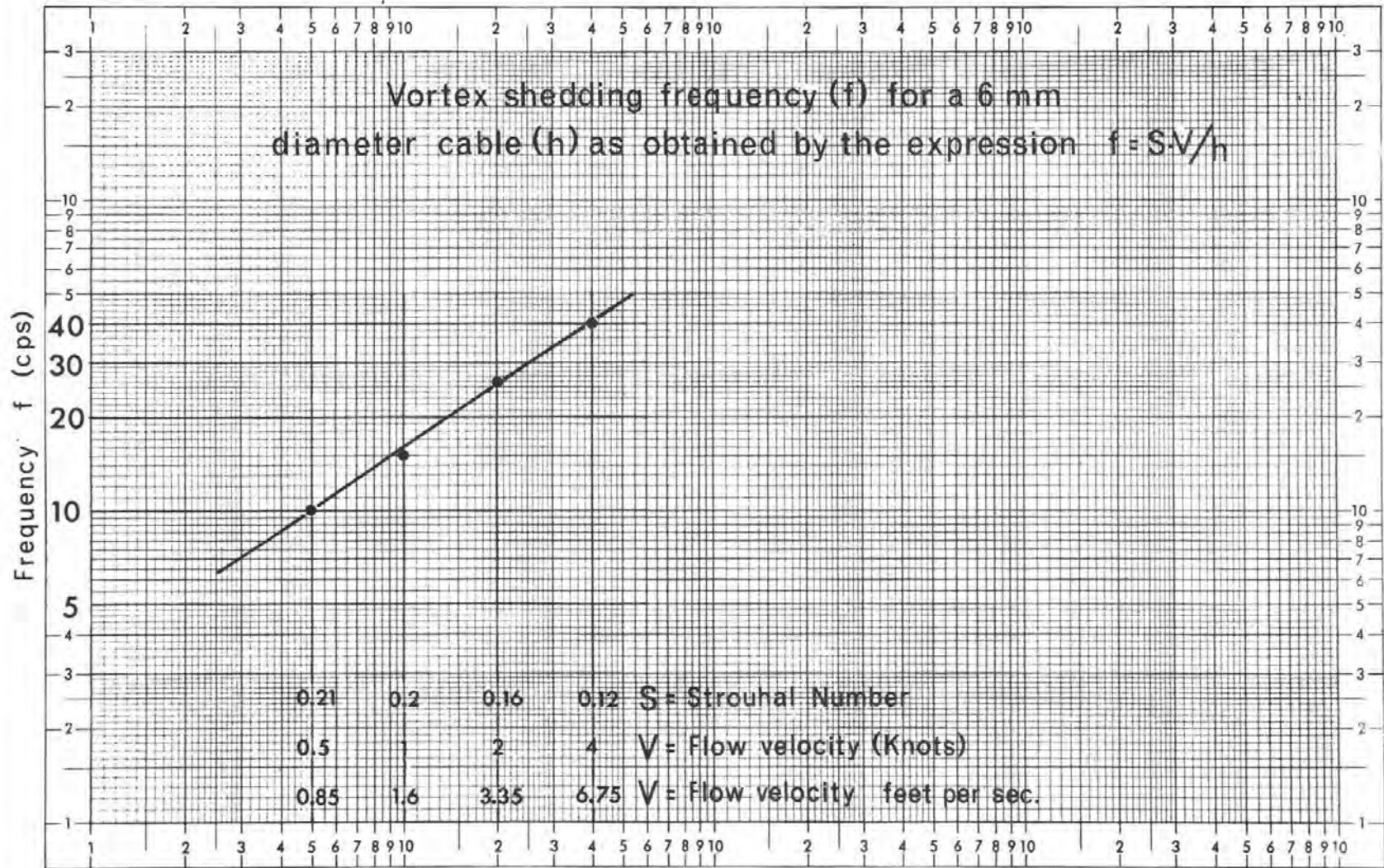
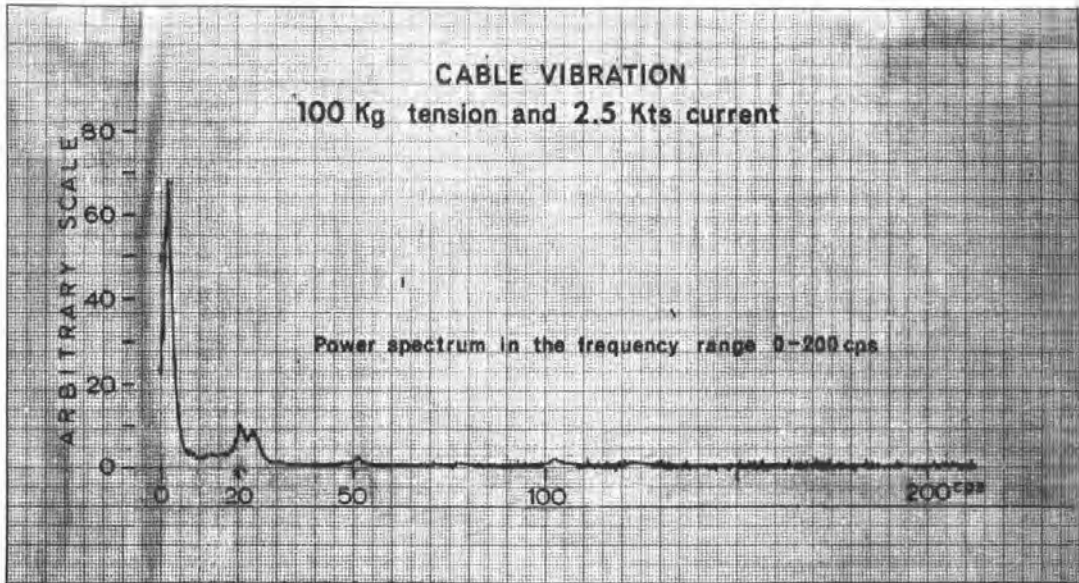


FIG. 6.1



a



b

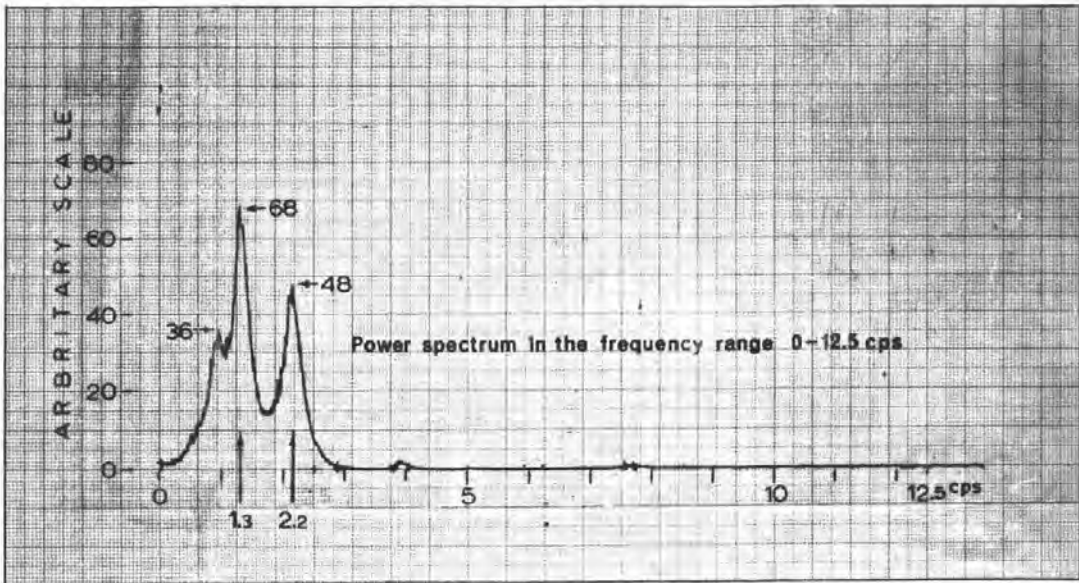
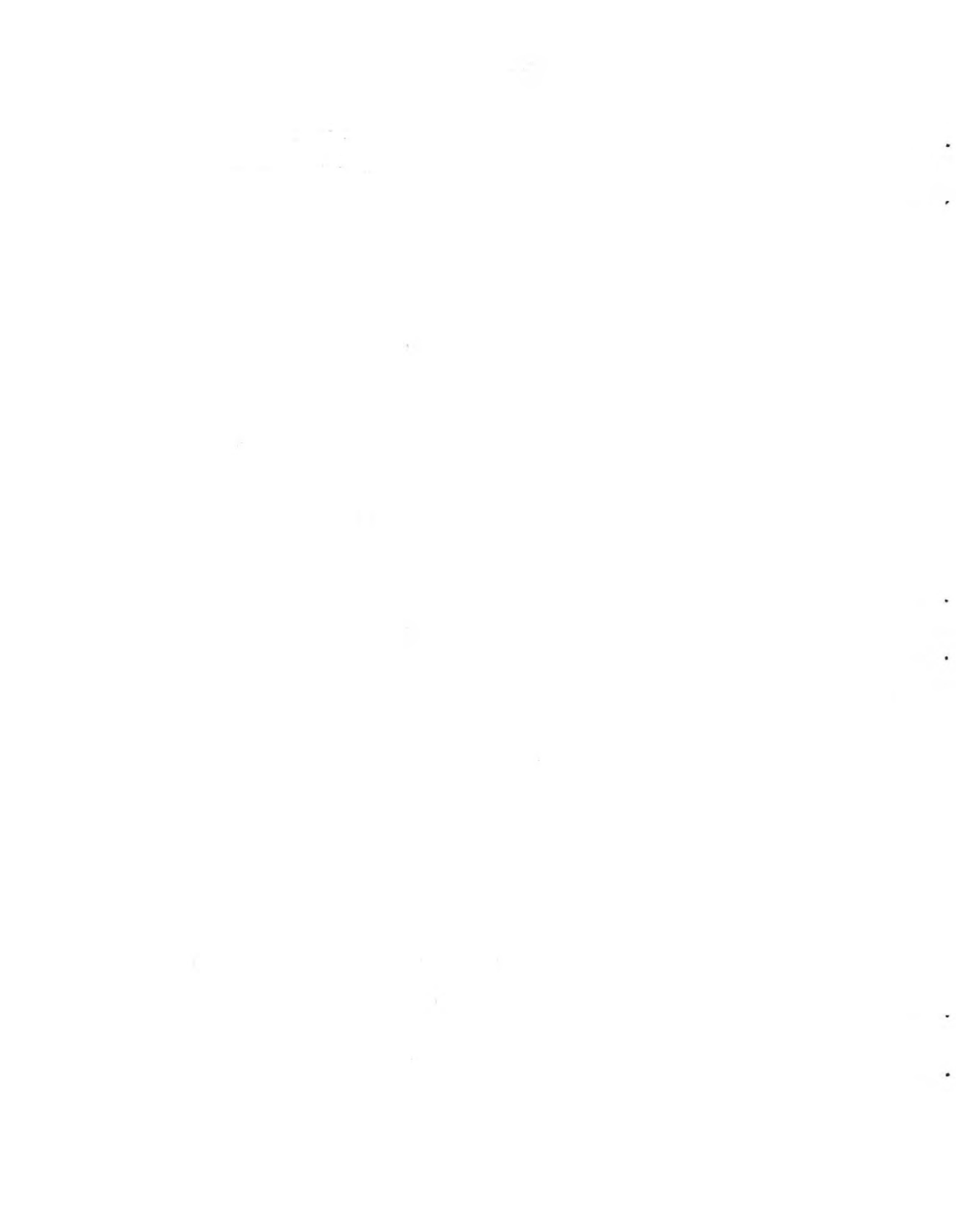


FIG. 6.2



## REFERENCES

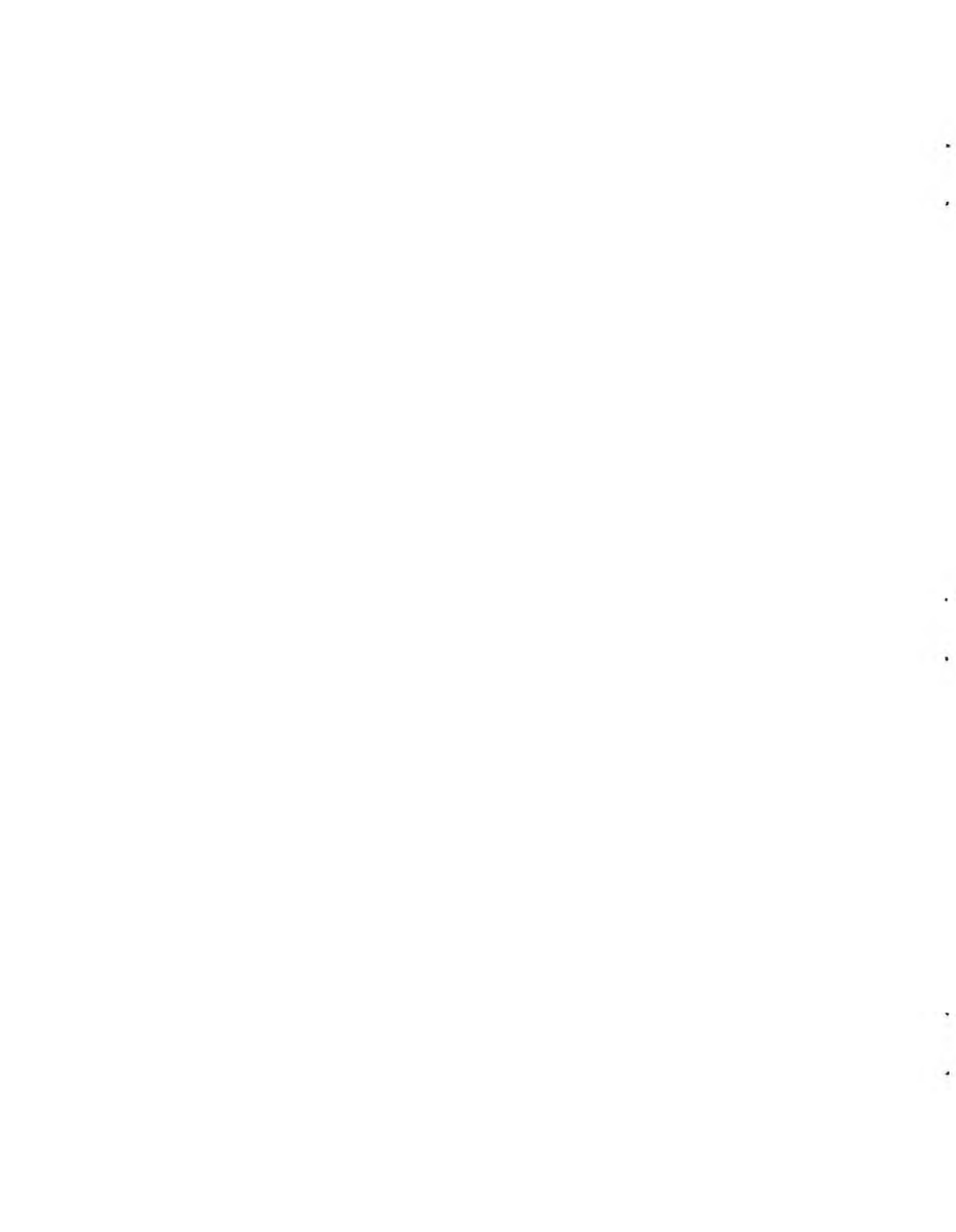
1. R. Frassetto and R. Pesaresi, "An Acoustic System for Releasing Submerged Oceanographic Buoys from their Anchors on Demand, Using a 1.4 kc Compact Source," SACLANTCEN T.R. 19, December 1963, NATO UNCLASSIFIED.
2. R. Pesaresi and R. Frassetto, "An Analogue Recording System for Recording Pulse Series," SACLANTCEN T.R. 24, April 1964, NATO UNCLASSIFIED.
3. R. Frassetto, V. Manzotti, and A. Chiarabini, "New Mechanical Equipment for Handling Oceanographic Cables," SACLANTCEN T.R. 26, April 1964, NATO UNCLASSIFIED.
4. R. Pesaresi and R. Frassetto, "A Compact Thermometer for the Study of Microthermal Structure from Oceanographic Buoys," SACLANTCEN T.R. 46, October 1965, NATO UNCLASSIFIED.
5. R. Frassetto, "A Neutrally-buoyant, Continuously Self-recording Ocean Current Meter for use in Compact, Deep-moored Systems," SACLANTCEN T.R. 63,
6. H.F. Olson, "Acoustical Engineering," D. Van Nostrand Co. In., Princeton, New Jersey.
7. A.D.K. Laird, "Circular Cylinders Oscillating in Water," Trans. Amer. Geoph. Union 36-2, April 1955, pp 279-285.
8. Marine Technology, Vol. 1, No. 2, December/January 1964-1965, Engineering Reference File.





## BIBLIOGRAPHY

- M. Blackburn, "Unmanned Moored Station Systems for Oceanography and Meteorology," Trans. Amer. Geoph. Union, Vol. 44, No. 2, pp 595-598, June 1963.
- R. Devereux et al, "Development of a Telemetering Oceanography Buoy," Progress Report, General Dynamics, Convair, 1963.
- N.P. Fofonoff, "A Technique for Analyzing Buoy System Motion," Geo Marine Technology, Vol. 1, No. 7, 1965.
- H.M. Hoover, "Wire Rope," G.M.T., Vol. 1, No. 3, 1965 (for 1 x 43 strand, rotation under load is minimum).
- J.D. Isaacs et al, "Deep Sea Moorings, Design and Use with Unmanned Instrument Stations," University of California, Press-Berkeley, 1963.
- R.G. Paquette and B.E. Henderson, "The Dynamics of Simple Deep-sea Buoy Moorings," G.M. Defence Research Laboratory, T.R. 65-79, November 1965.
- W.S. Richardson, P.B. Stimson and C.H. Wilkins, "Current Measurements from Moored Buoys," Deep Sea Res., Vol. 10, pp 369-388, 1963.
- R.M. Snyder, "A Practical Approach to Hydrodynamic Drag," G.M.T., Vol. 1, No. 4.



## DISTRIBUTION LIST

### MINISTRIES OF DEFENCE

Minister of Defence  
Brussels, Belgium 10 copies

Department of National Defence  
Ottawa, Canada 10 copies

Chief of Defence  
Copenhagen, Denmark 10 copies

Minister of National Defence  
Paris, France 10 copies

Minister of Defence  
Federal Republic of Germany  
Bonn, Germany 12 copies

Minister of Defence  
Athens, Greece 10 copies

Minister of National Defence  
Rome, Italy 10 copies

Minister of National Defence  
The Hague, Netherlands 10 copies

Minister of National Defence  
Oslo, Norway 10 copies

Minister of National Defence  
Lisbon, Portugal 10 copies

Minister of National Defence  
Ankara, Turkey 10 copies

Minister of Defence  
London, England, U K 20 copies

SECDEF United States  
(through USNLO to SACLANTCEN,  
ONR, London) 70 copies

### NATO AUTHORITIES

SECGEN NATO  
(through MCREP)  
Paris, France 5 copies

NATO Military Committee  
Washington D.C. 20301 3 copies

ASG for Scientific Affairs NATO  
Paris, France 1 copy

SACLANT  
Norfolk, Virginia 23511 3 copies

SACEUR  
Paris, France 7 copies

CINCHAN  
Ft. Southwick, Fareham  
England 1 copy

SACLANTREPEUR  
Paris, France 1 copy

COMAIRCHAN  
Northwood, England 1 copy

CINCAFMED  
Malta G.C. 1 copy

CINCEASTLANT  
Eastbury Park  
Northwood, England 1 copy

CINWESTLANT  
Norfolk, Virginia 23511 1 copy

COMMAIREASTLANT  
Northwood, England 1 copy

COMSUBEASTLANT  
Ft. Blackhouse  
Gosport, England 1 copy

COMCANLANT  
H.M.C. Dockyard  
Halifax, Canada 1 copy

COMOCEANLANT  
Norfolk, Virginia 23511 1 copy

COMEDCENT  
Naples, Italy 1 copy

COMEDSQUEAST  
Malta G.C. 1 copy

COMSUBACLANT  
Norfolk, Virginia 23511 1 copy

COMSUBMED  
Malta G.C. 1 copy

Commander TASK FORCE 442  
FPO, N.Y. 09521 1 copy

SHAPE T.C.  
The Hague, Netherlands 1 copy

### SCIENTIFIC COMMITTEE OF NATIONAL REPRESENTATIVES FOR SACLANTCEN

SCNR Belgium 1 copy

SCNR Canada 1 copy

SCNR Denmark 1 copy

SCNR France 1 copy

SCNR Germany 1 copy

SCNR Greece 1 copy

SCNR Italy 1 copy

SCNR Netherlands 1 copy

SCNR Norway 1 copy

SCNR Turkey 1 copy

SCNR United Kingdom 1 copy

SCNR United States 1 copy

### NATIONAL LIAISON OFFICERS FOR SACLANTCEN

NLO France 1 copy

NLO Italy 1 copy

NLO Portugal 1 copy

NLO United States 1 copy

### NATIONAL LIAISON REPRESENTATIVES TO SACLANT

NLR Belgium 1 copy

NLR Canada 1 copy

NLR Denmark 1 copy

NLR France 1 copy

NLR Germany 1 copy

NLR Greece 1 copy

NLR Italy 1 copy

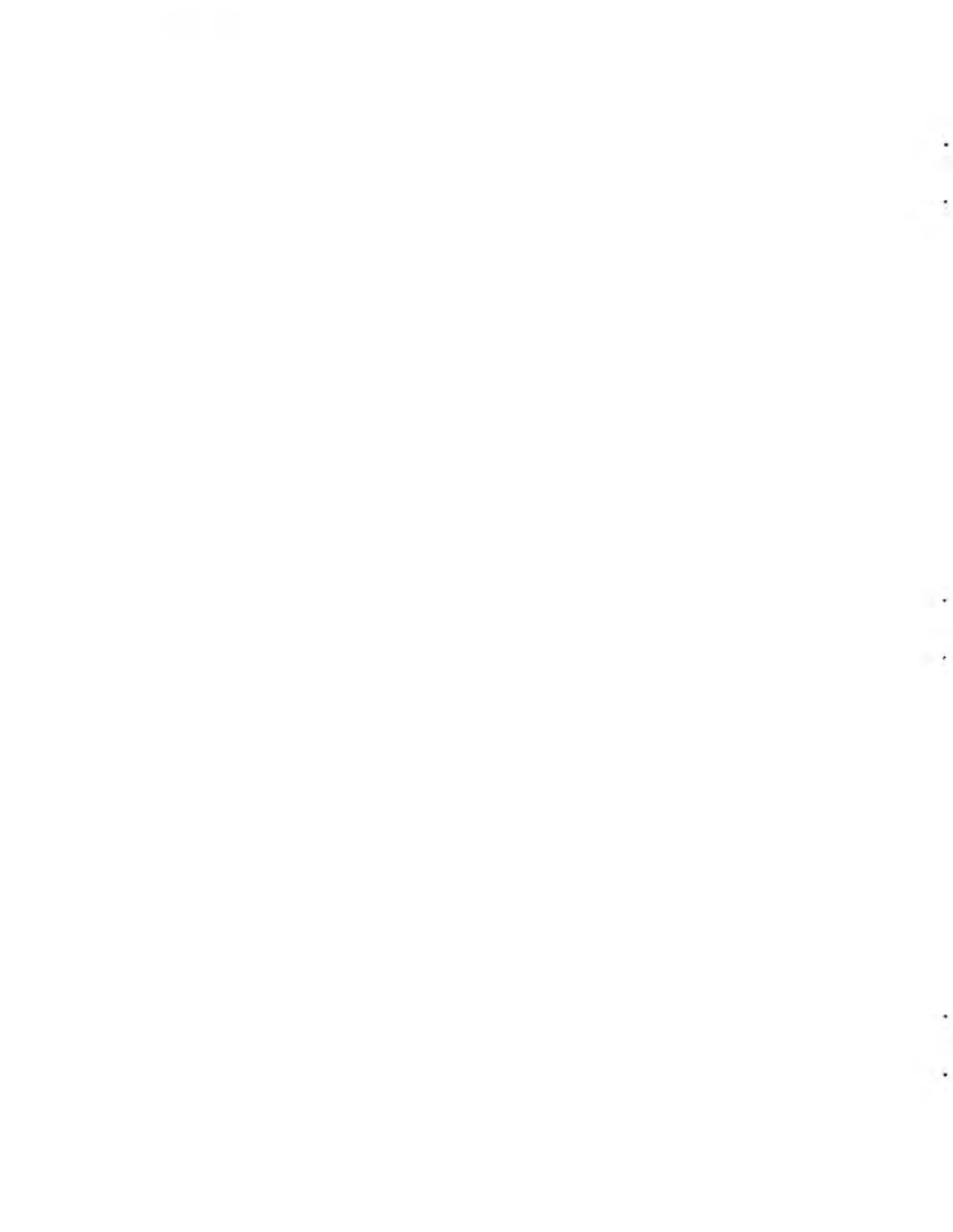
NLR Netherlands 1 copy

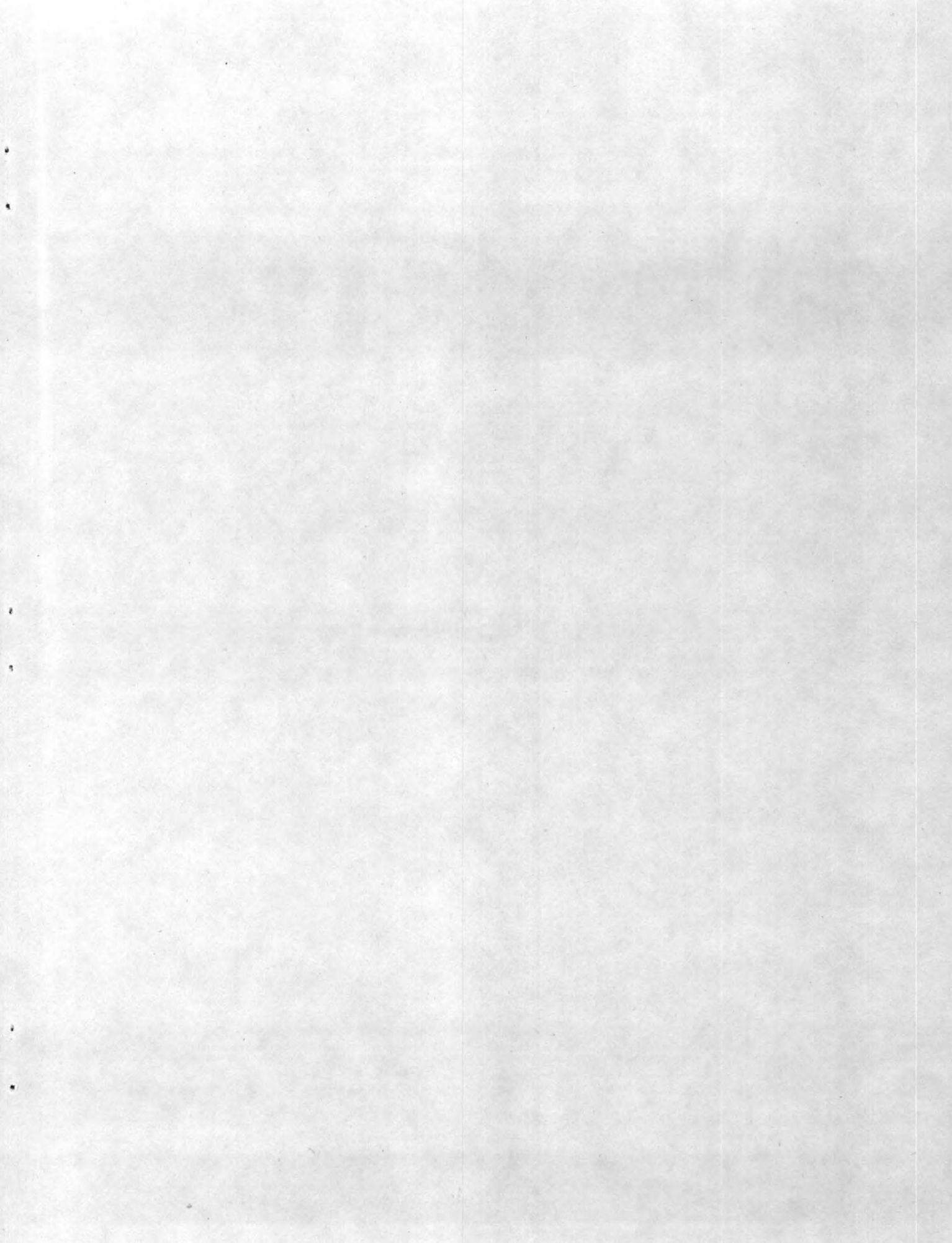
NLR Norway 1 copy

NLR Portugal 1 copy

NLR Turkey 1 copy

NLR United Kingdom 1 copy





NATO UNCLASSIFIED

NATO UNCLASSIFIED