

SACLANT ASW RESEARCH CENTRE
LIBRARY COPY

#2

SACLANT ASW
RESEARCH CENTER

AN ACOUSTIC SYSTEM FOR RELEASING SUBMERGED
OCEANOGRAPHIC BUOYS FROM THEIR ANCHORS
ON DEMAND USING A 1.4 KC COMPACT SOURCE

by

R. FRASSETTO and R. PESARESI

1 December 1963

NATO

VIALE SAN BARTOLOMEO, 92
LA SPEZIA, ITALY

This document is released to a NATO Government at the direction of the SACLANTCEN subject to the following conditions:

1. The recipient NATO Government agrees to use its best endeavours to ensure that the information herein disclosed, whether or not it bears a security classification, is not dealt with in any manner (a) contrary to the intent of the provisions of the Charter of the Centre, or (b) prejudicial to the rights of the owner thereof to obtain patent, copyright, or other like statutory protection therefor.

2. If the technical information was originally released to the Centre by a NATO Government subject to restrictions clearly marked on this document the recipient NATO Government agrees to use its best endeavours to abide by the terms of the restrictions so imposed by the releasing Government.

NATO UNCLASSIFIED

TECHNICAL REPORT 19

SACLANT ASW RESEARCH CENTRE

Viale San Bartolomeo 92

La Spezia, Italy

AN ACOUSTIC SYSTEM FOR RELEASING SUBMERGED
OCEANOGRAPHIC BUOYS FROM THEIR ANCHORS
ON DEMAND USING A 1.4 KC COMPACT SOURCE

By

R. Frassetto and R. Pesaresi

1 December 1963

APPROVED FOR DISTRIBUTION

JOHN M. IDE

Director

NATO UNCLASSIFIED

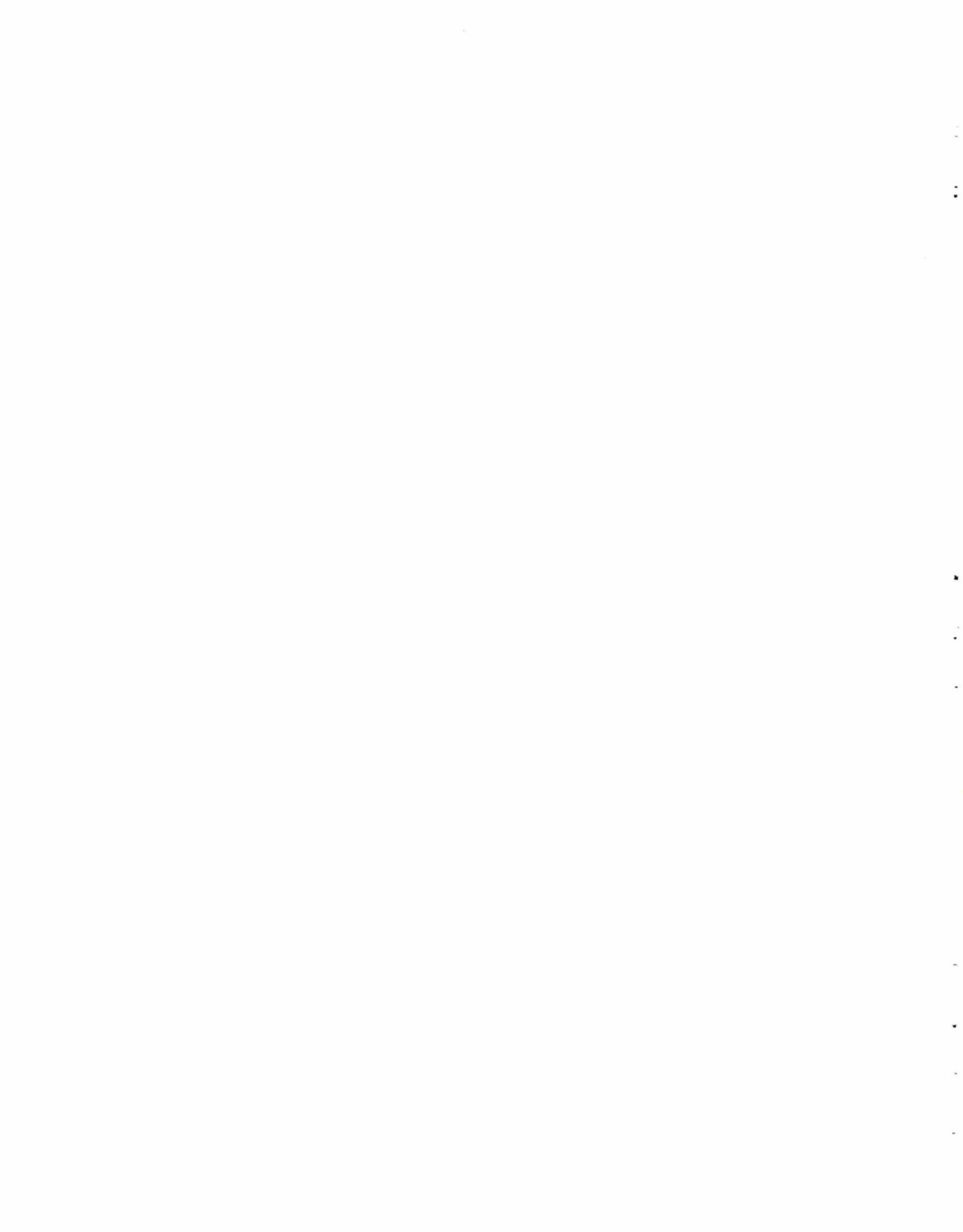

AN ACOUSTIC SYSTEM FOR RELEASING SUBMERGED
OCEANOGRAPHIC BUOYS FROM THEIR ANCHORS
ON DEMAND USING A 1,4 KC COMPACT SOURCE

By

R. Frassetto and R. Pesaresi

Summary

This paper describes an anchor-releasing device for the recovery of moored oceanographic equipment. The releaser is actuated by a remote acoustic signal emitted by a small and powerful 1400 cps sound source rather than by unsafe explosive charges. The acoustic power output of the source can be regulated according to the range of operation, up to a maximum of 400 watts. The submerged unit is self-contained, remains active for several months and is recovered together with the oceanographic equipment. Special steps have been taken to prevent false triggering of the releaser either by high or low level noise.

1. INTRODUCTION

Prototypes of meteorological and oceanographic buoys have been used at sea for the last few years. Vertical arrays of instruments, with self-recording or telemetering equipment and supported by surface or submerged buoys, are becoming more important for recording data over long periods and wide areas to permit synoptic work. Equivalent work carried out from ships is far more expensive and, in some cases, may be less accurate. With the advent of the moored buoy technique, which is being perfected in many countries, the problem arises of recovering valuable instruments, often containing recorded data.

Pulling on the mooring cable, to break a weak link or to pull up the anchor, is a difficult and delicate operation which involves the risk of losing the whole package. Systems for releasing the mooring cable from its anchor are desirable for the recovery of surface buoys, but they are essential for the recovery of subsurface buoys or deep water instruments which have no link with the surface, as is the case presented in this paper. A few releasing devices, designed by some oceanographers and others, available commercially, use an explosive charge as signal to trigger an explosive link near the anchor. However, explosive devices are not considered always practical or safe, and many ships are not allowed to carry explosives. Consequently, a safe and practical releasing apparatus, which does not use explosives, was conceived.

The idea of using a compact and powerful single frequency sound source as a triggering device occurred to the author at Hudson Laboratories in 1959 when such a source was made available by Mr. P. Weber. Subsequently, Dr. T. Pochapsky of Hudson Laboratories adapted this technique to release his neutrally buoyant instrumented buoys. His unit has a special application: it operates over short ranges and short periods and needs no special precaution to prevent false triggering.

This report presents a triggering technique which will release the anchor of any instrument attached to a lifting float. In designing this system, emphasis was given to operational safety, compactness, low cost, and reasonable maximum triggering range (5 mi, 4000 m depth). Insensitivity to accidental release, including the effect of explosive charges often dropped by research ships or fishermen, was also emphasized. It was also considered a requirement that the listening unit should be active over periods of a few months and capable of being used again and again indefinitely.

The system (Fig. 1) consists of two units:

1. A compact shipborne sound source, emitting a 1400 cps signal with a maximum acoustic power output of 400 w. (Figs. 2 and 3).
2. A self-contained acoustic receiver connected to a mechanical releaser. (Figs. 2 and 3).

The receiver is active for periods up to a few months depending on the capacity of the battery used.* Upon receipt of a 20 sec 1400 cps signal, an explosive** latch pin (squib) is fired to operate a mechanical releaser. The buoy then lifts to the surface, trailing its instruments and receiver, where it can be recovered.

The receiver is equipped with a filter and gate system to minimize the probability of false triggering from random background or ship noises.

*9 mercury batteries, total weight 1/2 lb, will keep the receiver activated for about 80 days.

**Explosive latch pin are sealed and no external effects of the primer cap are produced; therefore, the unit is safe to operate.

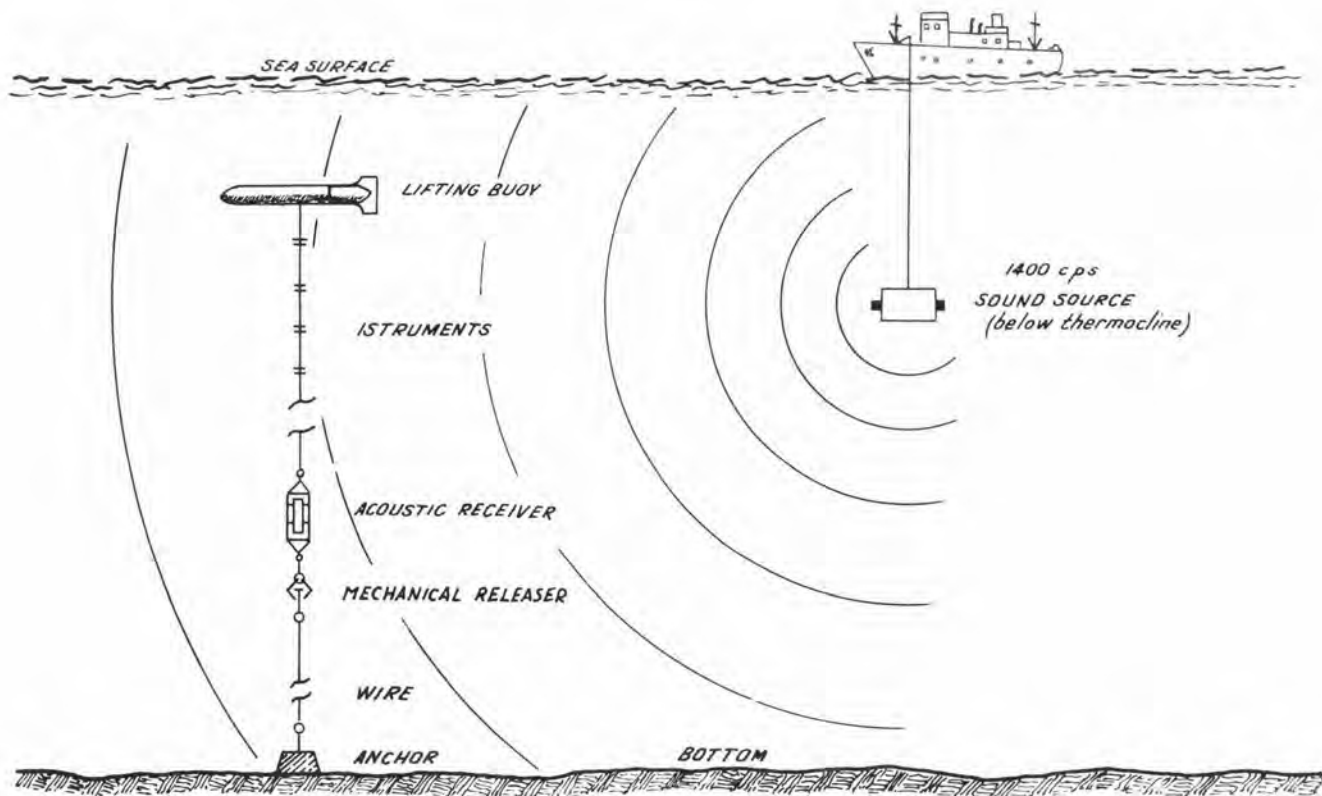

Fig. 1 Anchor Releasing System:

The acoustic receiver, at the end of the array of instruments fires the mechanical releaser when a 1400 cps signal, emitted by the ship's source, is received free of noise.

The wire end of the anchor drops to the bottom while the buoy lifts to the surface trailing the instruments.

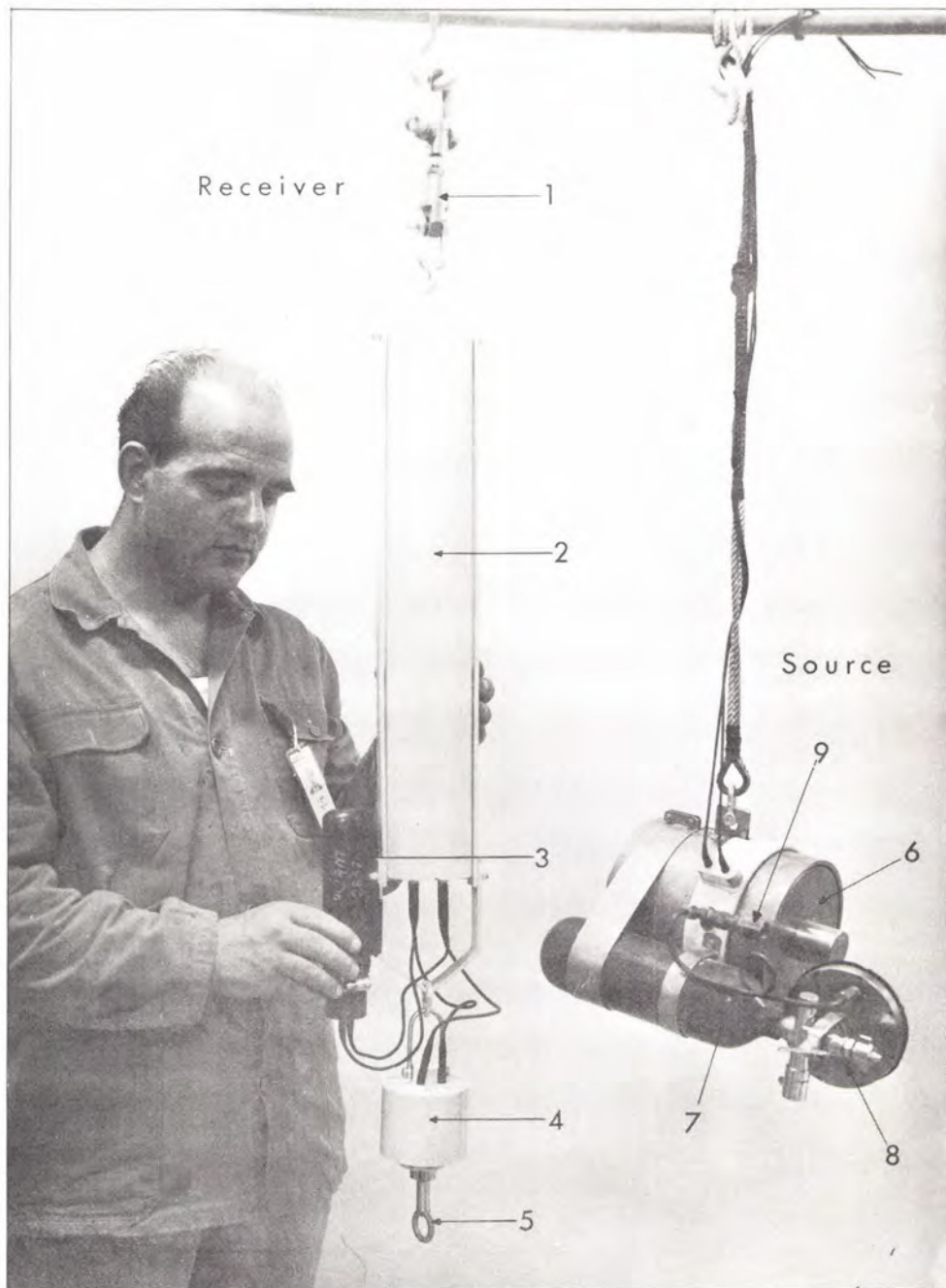

Fig. 2 View of Source and Receiver - The compressed air bottle and valves outside the source permit equalization of pressure in function of depth.

- | | |
|--|------------------------------------|
| 1. Mechanical ball bearing swivel | 5. Anchor line head to be released |
| 2. Container of electronics | 6. Vibrating plates of source |
| 3. Hydrophone | 7. Compressed air bottle |
| 4. Squib container (Mechanical releaser) | 8. Demand valve |
| | 9. Exhaust valve |

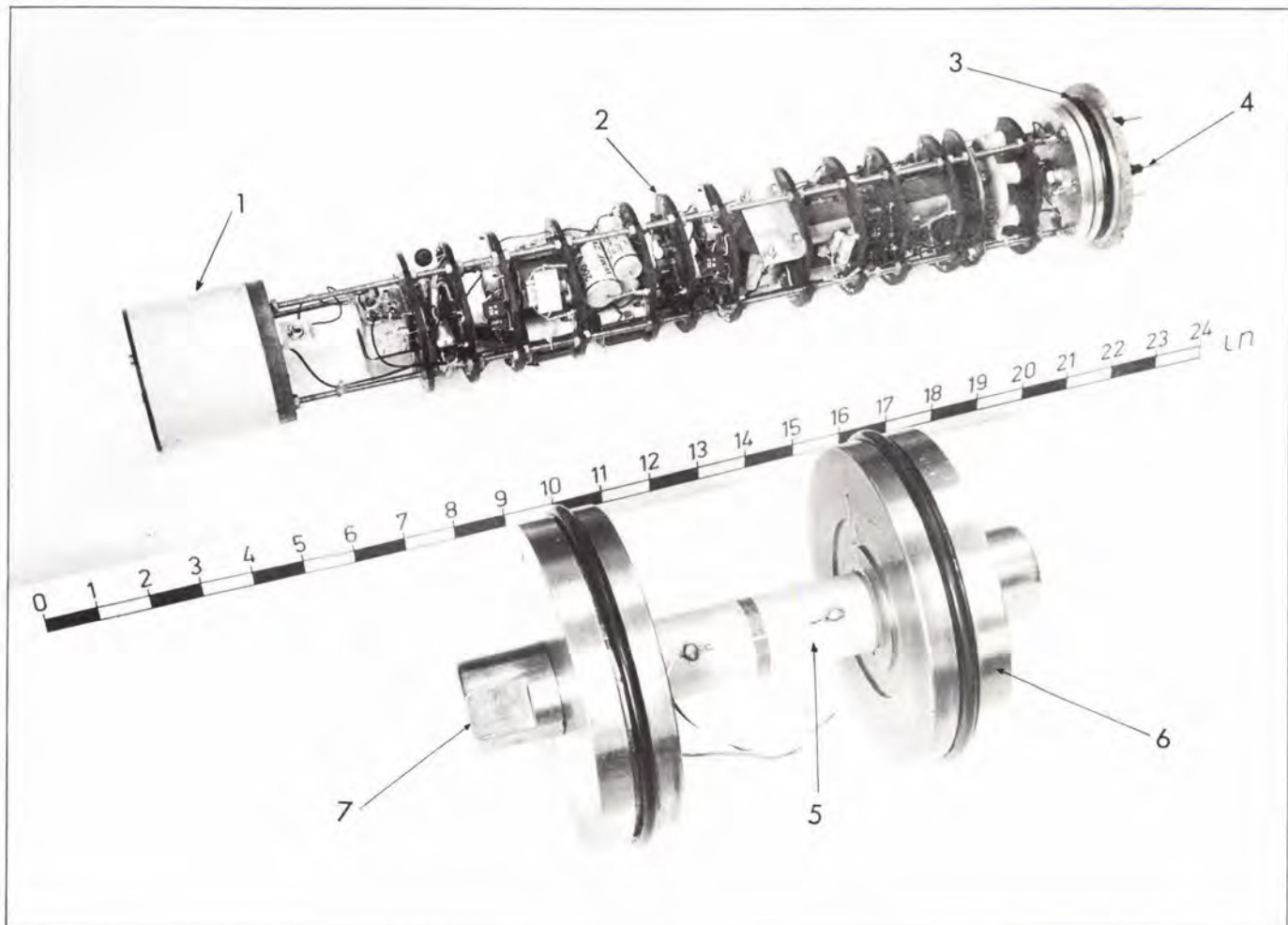

Fig. 3 Inside View of the Source and Receiver

1. Power supply package (9 mercury batteries Mallory 1.35 v 14 Ah) for 90 days continuous operation
2. Electronics
3. End plate (Alluminium RR 77) with o ring
4. Pressure connector (Mecca plugs)
5. Lead zirconate PZT 4 crystals wired in serie
6. End plates, stainless steel: 11.6 lbs each
7. Heads with o ring seals, keep the end plates tighten on the faces of the crystals by mean of a bronze bolt on the axis of the unit

2. ACOUSTICAL CONSIDERATIONS

In normal ambient conditions, one can reasonably expect that a 200 w acoustic signal, emitted by an omnidirectional source resonating at about 1400 cps and placed below the thermocline, will produce a sound pressure signal level L of 14 dB re 1 dyne/cm² at a distance of 10 km. This is shown in the following formulas (2.1) to (2.4):

$$10 \log Pa = 20 \log p - 70.9 = S - 70.9 \quad (2.1)$$

(Ref. 2 - Par. 2.1) where

Pa = acoustic power output in watts

p = acoustic pressure in dynes/cm² at 1 m

S = source level in dB re 1 dyne/cm² at 1 m

By approximating from formula (2.1),

$$S = 10 \log Pa + 71 \text{ (dB)}$$

and, by substituting the value (200 w),

$$10 \log 200 + 71 = 94 \quad (2.2)$$

which is the source level in dB at 1 m distance. As a function of distance, this level decreases as shown in Fig. 4 in accordance with the following formula:

$$L_D = S - 20 \log D \quad (2.3)$$

(Ref. 1 - Par. 4) where L_D is the sound pressure level at distance D, S is the source level (dB), and D is the distance in metres.

Substituting the values in (2.3) we obtain:

$$L_D = 94 - 20 \log. 10,000 = 14 \text{ dB re dyne/cm}^2 \quad (2.4)$$

A few systems were tested to find the best method to prevent false triggering caused by random background noise, underwater explosions, or high level ship-noise. Pulse modulated signals did not give good results; they were considered impractical because a simple and inexpensive electronic circuit would not be capable of deciphering the distorted signals received. Other code systems were also found to involve complicated, expensive and power-consuming electronics. An efficient and dependable solution was found by using two narrow band filter-amplifiers: one, the actuator, centred at 1400 cps (signal frequency), and the other, at about 900 cps, acting as inhibitor when noise is mixed with the signal. In addition a 10 sec time constant was applied to eliminate effects of unwanted signals of short duration.

High level ship-noise, in the region of 1400 cps, is the greatest hazard to our system. The maximum ship-noise in this frequency region had to be determined before designing the electronic circuit of the receiver. Simplified formulas found in Ref. 2 were considered suitable for our purpose. From these it was found that extreme values of observed overall source level (0.1 to 10 kc) at 1 m from a very large ship (100,000 tons) or a battleship at 30 knots is 110 dB, which would correspond to about 91 dB in the 0.8 - 1 kc band

(Ref. 2 - Par. 7.4).*

In Fig. 4 the maximum ship noise level in the $900 \text{ cps} \pm 100$ is shown as a function of distance. It can be seen, at 200 m distance (which is the minimum depth for a releaser on the cable of a moored buoy), that this noise level is about 44 dB, which is also the maximum signal level considered for calculation purposes with the 1400 cps source at 300 m distance. However, in practice, to avoid a collision between the lifting buoy and the ship, a distance of 500 to 1000 m is advisable.

To summarize: in designing the amplifiers of the receiver, it was decided to take the following ranges of signal and noise for applications in water shallower than 2000 m. (See Fig. 4).

1.4 kc Signal	Noise in the 0.8 - 1 kc Band
Max (Watt = 200) 44 dB (D = 300 m)	Max 44 dB (D = 200 m)
Min (Watt = 1) 10 dB (D = 1000 m)	Min 10 dB (D = 10,000 m)

(Sea state and biological noise levels are well below this minimum)

Thus, the dynamic range of the receiver should not be less than 34 dB (44 - 10 dB).

*Overall noise level = 110 dB (Ref. 2 - par. 5.32)

Spectrum level at 900 cps is $110 - 41.5 = 68.5$ dB (noise per cps) for a spectrum slope of 7 dB per octave

$68.5 + 10 \log 200 = 91.5$ dB = noise in the 0.8 - 1 kc band.

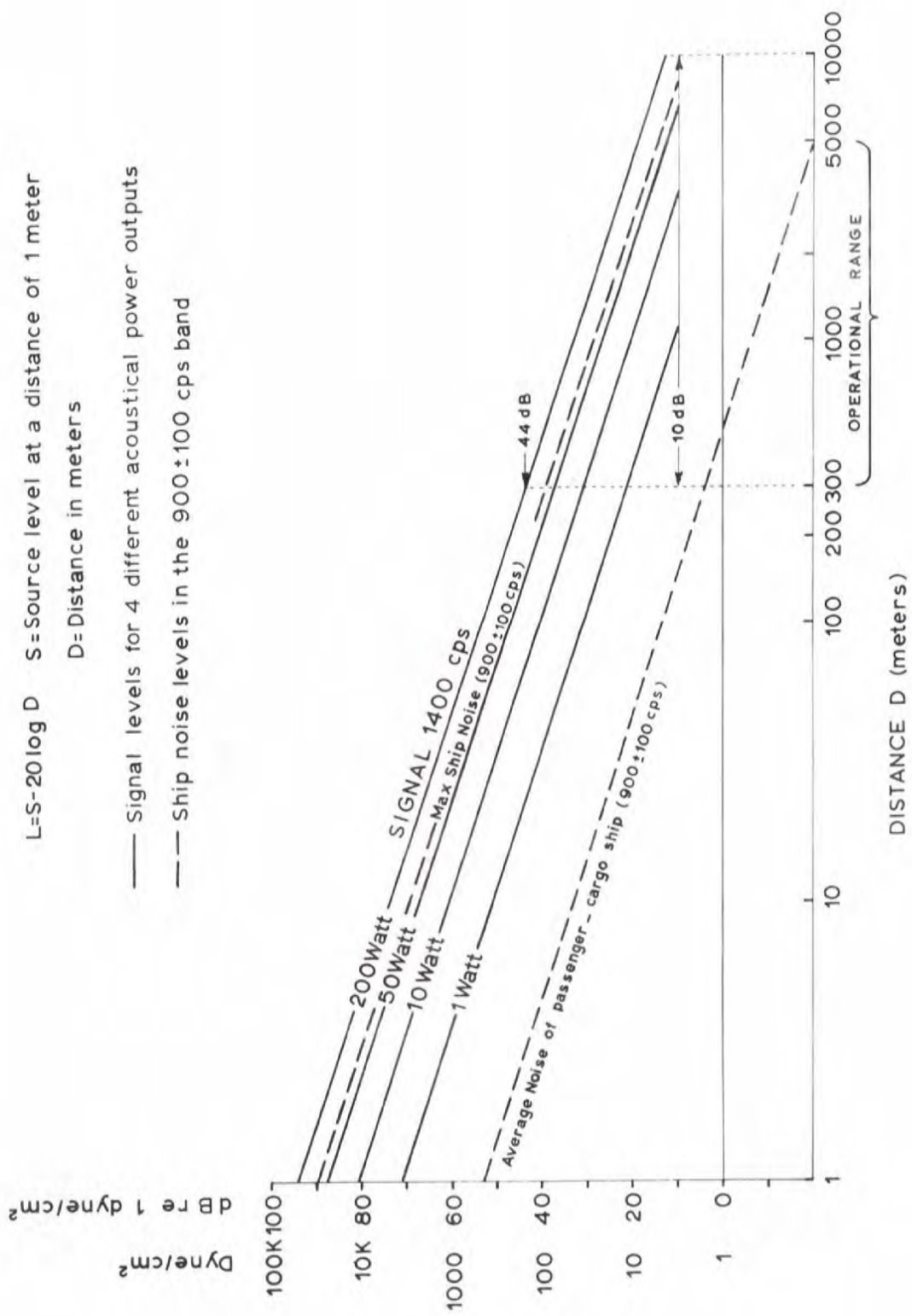

Fig. 4 Signal Level Versus Distance

3. SOUND SOURCE (Figs. 2 and 3)

The sound source is a lightweight dual piston transducer using two lead zirconate cleviste PZT4 cylinders. The unit is made to resonate at 1.4 kc and is capable of radiating a maximum of 400 acoustic watts. It was designed and built at Hudson Laboratories, Columbia University (Ref. 3).

Some characteristics are as follows:

Overall length	30 in
Diameter	$6\frac{1}{2}$ in
Weight in air	54 lb
Weight of each end plate	11 lb
Cylinder length	6 in
Cylinder diameter	3 in
Wall thickness	1/8 in
Power input up to	0.900 kw
Efficiency	3.5 dB
Directivity Index	4 dB
Impedance	$Z_0 = 500 \Omega$ (at resonance frequency)

When the external water pressure increases, a demand valve, connected with an air pressure bottle, feeds air into the transducer case and permits safe operation of the unit at considerable depths. During ascent, the internal pressure is released through an exhaust valve which operates with a differential

pressure of $1/2 \text{ kg/cm}^2$. With this device, the transducer will normally be operated below the thermocline to take advantage of the best conditions of sound propagation at long ranges.

The driving system is represented by a 1 kw Savage power amplifier (Fig. 5) which, with the necessary impedance transformer and variable inductance control, can actually supply 600 - 700 w of electricity to the source.

Sea tests have proved that an acoustic power output of about 200 w is sufficient for releasing the buoy at distances up to 10 km. The corresponding electric power needed to drive the transducer is 450-500 w.

3.1 Results of Some Tests at Sea

3.1.1 The transducer, driven at a given power, has an instability of resonant frequency which fluctuates in a band of about 10 cps ($1400 \text{ cps} \pm 5$). The cause of this fluctuation has not yet been determined: it could be mechanical, or it could be an effect of hydrostatic pressure. Nevertheless, this is not a serious defect for our application, because the output power of the sound source does not change by more than a few percent.

3.1.2 By varying the driving power on the transducer, it was found that the resonant frequency, the impedance, and the inductance of the transducer decreased as the driving power increased.

The following table shows some of the results:

	Driving Power Watts	Voltage volts	Frequency cps	Impedance Ohms	Inductance Henry
Savage	1.1	25	1450	560	0.200
	4.5	50	1442	560	0.198
	20.0	100	1440	500	0.189
	85.0	200	1435	470	0.186

These results led to the design of a control unit (Fig. 5) for the driver in which a variable inductance was placed in series. By varying the inductance L (175 to 210 h in 5 mh steps), we manage to keep the unit in resonance and, consequently, to maintain the power output near its maximum.

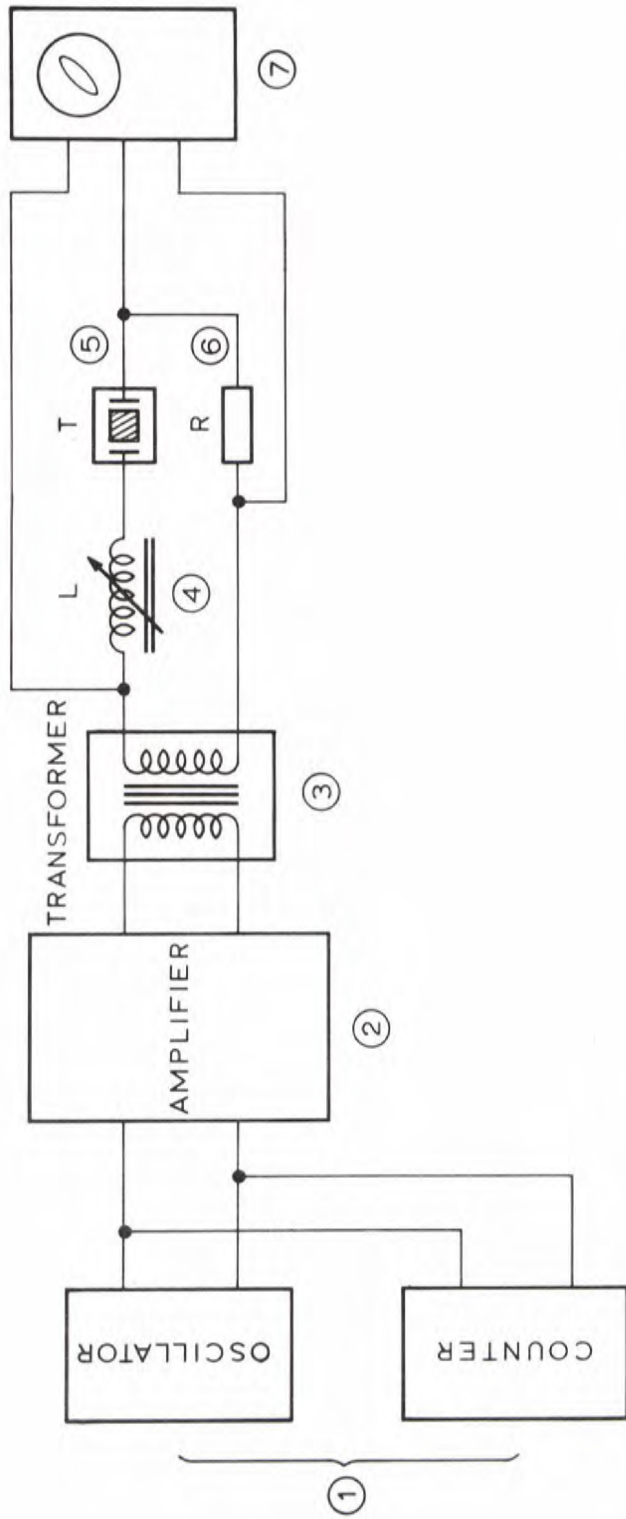

- ① INPUT FREQUENCY CONTROL: VARIABLE FREQUENCY OSCILLATOR (HEWLETT PACKARD MODEL 200 CD) AND FREQUENCY COUNTER HEWLETT PACKARD MODEL 522 B.
- ② SAVAGE 1 kw POWER AMPLIFIER WITH OUTPUT IMPEDANCE 100Ω - 330 V - TYPE KM 2Z - MK II.
- ③ INPHISYL TRANSFORMER WITH OUTPUT IMPEDANCE 500Ω TO MATCH SOUND SOURCE IMPEDANCE. $V \approx 740$ - OUTPUT POWER = 500 - 600 W.
- ④ L INPHISYL VARIABLE INDUCTANCE (8 POSITIONS FROM 175 to 210 mH, 5 mH STEPS).
- ⑤ T 1400 cps RESONANT SOUND SOURCE.
- ⑥ R RESISTANCE = 1Ω FOR RESONANCE REFERENCE.
- ⑦ OSCILLOSCOPE (FOR CONTROL OF RESONANT FREQUENCY).

Fig. 5 Driving Unit for Shipborn Source

In practice, the transducer T(5) is driven to give an acoustic power output which does not exceed 200 watts.

4. THE RECEIVING UNIT

4.1 The Hydrophone (Ref. 4)

The hydrophone, made of barium titanate cylinders wired in series and potted with epoxy resin in a rubber boot to permit operation in deep water, has these characteristics:

Open circuit sensitivity	between -92 and -96 dB re $v/\text{dyne}/\text{cm}^2$ in the 0.8 to 1.6 kc octave band (temperature and pressure influence sensitivity)
Capacitance	4 to 4.2 nf
DC Resistance	10 meg
Maximum Static Pressure	100 kg/cm^2

The hydrophone is mounted alongside the receiver case with shock cord.

4.2 The Receiver

The receiver, mounted inside an inexpensive, pressure resistant aluminum tube 70 cm long, (Fig. 2) is presented in block diagram by Fig. 6. When the buoy is to be recovered, a continuous 1400 cps sound wave is transmitted into the water from the laboratory ship (Fig. 1). The signal is picked up by the hydrophone, amplified in a preamplifier and fed to a high pass filter with a cut off frequency of 900 cps. A high pass filter has been selected at this stage because it also prevents saturation of the succeeding amplifiers by the continuous low frequency noise of the vibrating cable. This saturation may produce higher harmonic effect which could cause a misfire of the anchor releaser. Following this filter, the receiving system is divided in two channels: an actuator,

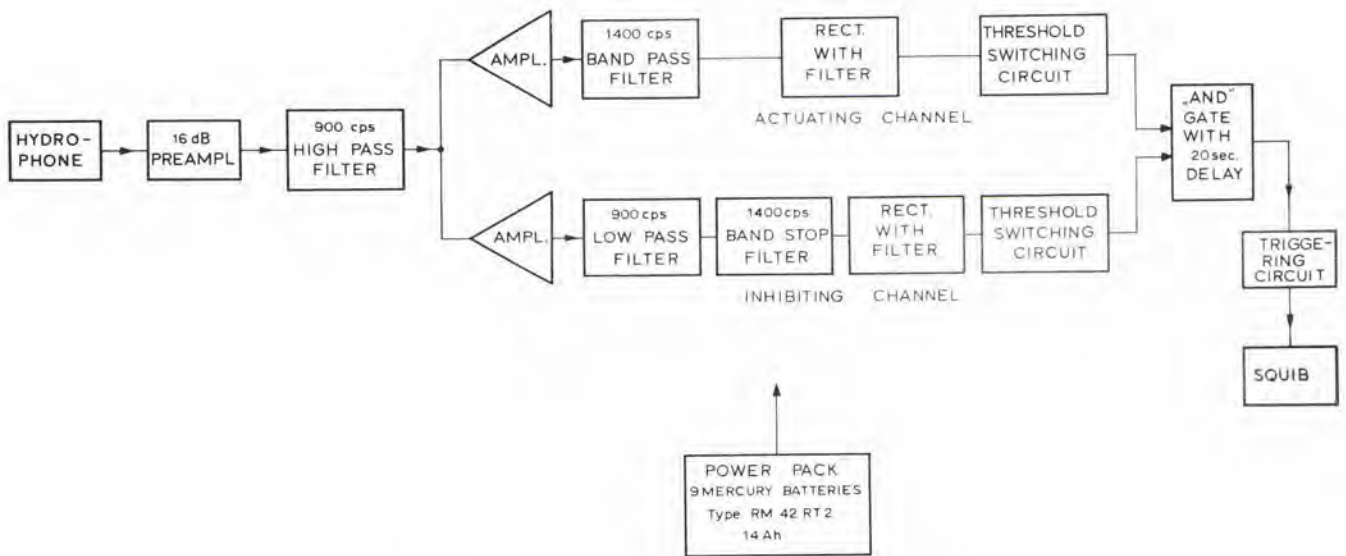

Fig. 6 Block Diagram of the Receiver

and an inhibitor (Fig. 6). The first, the actuating channel, has a band pass filter with a centre frequency of 1400 cps; while the other, the inhibiting channel has a low pass filter with a cut off frequency of 900 cps and a band stop filter with the centre frequency at 1400 cps (Fig. 6).

The 1400 cps signal passes through the amplifiers and the filter of the actuating channel before being rectified and filtered in the rectifier circuit. Provided the signal level is sufficiently high, the threshold switching circuit, which normally clamps the "and" gate, will switch and thereby remove the clamping voltage. The "and" gate is provided with a delay circuit and will not open unless the signal is continuous for approximately 20 seconds.

The inhibiting channel of the receiver is used to avoid faulty triggering of the squib due to noise signals from ships passing in the vicinity of the buoy.

This channel is designed to act in the opposite way to that of the 1400 cps channel. Provided the level of a 900 cps noise signal is sufficiently high, the threshold switching circuit will switch on and clamp the "and" gate. On the other hand, when no signal (or an insufficient signal) is present in the 900 cps channel, the threshold switching circuit will not clamp the "and" gate.

Thus, the requirements for actuating the squib are:

1. A sufficiently large signal present in the 1400 cps channel
2. A duration of 20 seconds or more of the 1400 cps signal
3. No signal (or an insufficient signal) present in the 900 cps channel

When all conditions are present the gate opens, the triggering circuit is actuated, and a suitable current is passed through the squib which, in turn, releases the buoy from its anchor.

In determining the necessary overall voltage gain of the receiver we must consider:

1. The sensitivity of the hydrophone, which in our case is -94 ± 2 dB re 1 v/dyne/cm²
2. The minimum voltage levels, as measured across the input terminals of the rectifiers (Figs. 6 and 7), required to actuate and inhibit the triggering circuit, which in this unit is 2.5 v corresponding to 8 dB re 1 v.

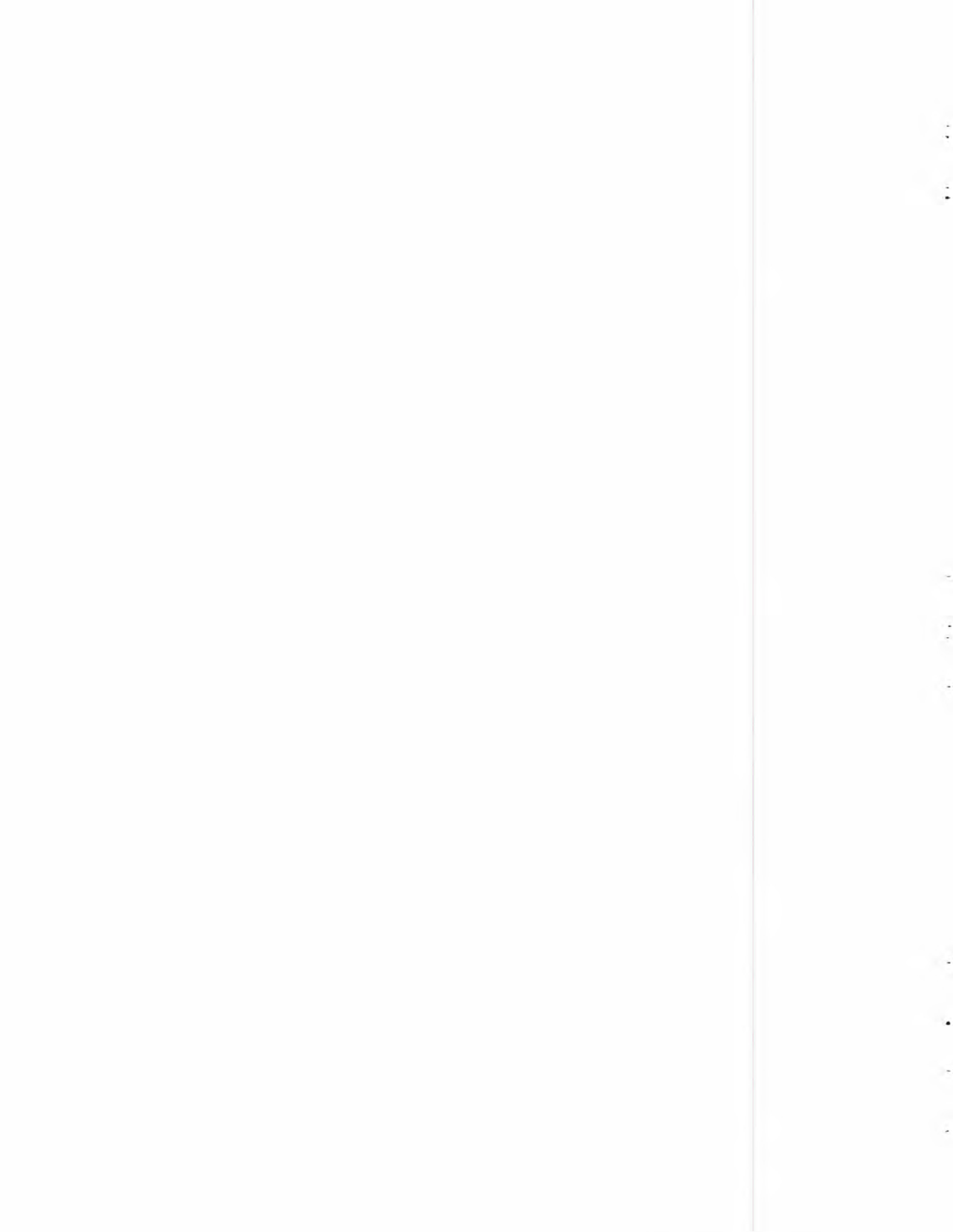

In this unit, the required 2.5 v. was obtained by using a gain (G_a) of 92 dB for the actuating channel and a gain (G_i) of 89 dB for the inhibiting channel. The 3 dB difference is accounted for by the difference between the 10 cps frequency band (Δf_a) of the actuating channel and the 200 cps frequency band (Δf_i) of the inhibiting channel, and by the introduction of a 10 dB safety factor.

The values of these gains were calculated as follows :

G_a . The minimum level of the 1.4 kc acoustic signal permitted to actuate the releaser had been set at 10 dB (p. 9). Therefore, considering this, the sensitivity of the hydrophone, and the minimum voltage levels, it is seen that

$$G_a = 8 - (10 - 94) = 92 \text{ dB} \quad (4.1)$$

G_i . If an unwanted noise is not to actuate the triggering circuit, it must generate a greater voltage at the output of the 900 cps inhibiting channel than at the output of the 1400 cps actuating channel. For white noises this is expressed as

$$10 \log \Delta f_i + G_i > 10 \log \Delta f_a + G_a \quad (4.2)$$

With ship noises, there is usually more noise around 900 cps than around 1400 cps and the system remains safe, but, as a protection, a safety factor of 10 dB was allowed; thus

$$10 \log \frac{\Delta f_i}{\Delta f_a} - (G_a - G_i) = 10 \text{ dB} \quad (4.3)$$

and, with the selected frequency bands,

$$G_a - G_i = 3 \text{ dB} \quad \text{and} \quad G_i = 89 \text{ dB}$$

The complete schematic diagram of the receiver is given in Fig. 8. The hydrophone is connected to the preamplifier which consists of the RC-coupled low noise transistor T-1 in grounded emitter configuration. This amplifier has a voltage gain of 16 dB and is connected to the high pass filter L1, L2, C3, C4, C5 with a cut off frequency of 900 cps.

Transistor T-2 is a RC-coupled amplifier stage in grounded emitter configuration with a voltage gain of approximately 20 dB. Following this amplifier is the band pass filter with centre frequency 1400 cps and band width 10 cps. The output circuit of the filter is connected to the two-stage, RC-coupled amplifier T-3 - T-4. Both transistors are in grounded emitter configuration. The gain may be varied by means of R15; the maximum gain is about 60 dB.

The diodes D1 and D2 form a peak-to-peak rectifier connected to the input of the threshold switching circuit T-8 - D3 - T-9. Normally these transistors are not conducting and the dc voltage level at the collector of T-9 is then 12 v (approximately). When this situation exists, diode D7 is forward biased and presents a fairly low resistance to the current passing through R31, D7, and R36. As R36 is about a hundred times as big as the total resistance of R31 and D7, the voltage level at the base of T-12 is only slightly less than 12 v and thus the gate T-12 - T-13 - D9 is clamped.

The Zener diode, D3 located in the emitter circuit of T-8, prevents the threshold circuit from switching until the voltage level at the base of T-8 drops below approximately 6.5 v. At this level the Zener diode will open and a current will flow in the collector circuit of T-8. Thereby, the base of T-9 becomes forward biased, and this transistor is switched on causing the collector voltage to drop from 12 to approximately 1.5 v. Diode D7 becomes reversely biased and loses its effect on the voltage level of T-12's base.

Assuming that no signal is present in the 900 cps channel, C30 will now be charged through R36 and the voltage level at the base of T-12 will (slowly) start dropping. About 20 sec later, when the voltage level has dropped to approximately 3.5 v, Zener diode D9 opens and T-13 starts conducting, thereby charging capacitor C31. When the voltage across C31 is approximately 0.6 v the silicon controlled rectifier SCR1 will fire and pass a current of 1 amp through the squib.

The 900 cps channel is quite similar to the 1400 cps but acts in the opposite way. The amplifier T-5, identical to T-2, is connected to the low pass filter L8, L9, C18, C20 with a cut off frequency of 900 cps and the band stop filter L10, C21 with centre frequency 1400 cps. Further, the two-stage amplifier T-6 - T-7 is identical to T-3 - T-4, and except for a phase inversion, the peak-to-peak rectifier D-4 - D-5 and the threshold switching circuit T-10 - D-6 - T-11 are similar to the corresponding circuits of the 1400 cps channel.

With no signal present in the inhibiting channel, the voltage level at the collector of T-11 is zero volts. Diode D8 is reversely biased and has no clamping effect on the gate. On the other hand, when a sufficiently large signal is present in this channel, T-11 will start conducting and the voltage level at the collector will increase to approximately 10.5 v.

Assuming also that T-9 is conducting, C30 will be charged through R36 as explained above. When the voltage level at the base of T-12 has dropped to approximately 10.5 v, diode D8 becomes forward biased and thus clamps the gate.

The output responses of the two channels, as measured across the input terminals of the rectifier circuits, are given in Fig. 7. During these measurements, a hydrophone with a capacitance of 1000 pf was connected to the receiver input circuit.

The dynamic range of the receiver may be defined as the difference between the 1400 cps and the 900 cps response curves at a frequency of 1400 cps. With a 3 dB relative gain between the channels, this difference is seen to be 43 dB but should, due to frequency drift, be considered as somewhat less, i. e., 40 dB. Signal levels below 10 dB are insufficient and will not operate the threshold switching circuit, while signal levels above 50 dB will operate the threshold switching circuits of both channels and thus clamp the "and" gate. By means of the gain controls of the two channels, the dynamic range may, of course, be changed, but formula (4.2) must be satisfied, and due consideration must also be given to the distribution of ship noise versus frequency. If the gain of the 1400 cps channel becomes too large, as compared to the gain of the 900 cps, the possibility of false triggering by ship noise will increase.

Temperature stability of the unit does not appear to be critical. In the temperature range from 10 to 25°C, it was seen that the gain of the actuating channel decreased as the temperature decreased. The effects of temperature changes may be shown in the following table:

T°C	Gain dB \pm 0.05	Frequency cps \pm 0.8
26.0	90.0	1401.8
17.3	88.8	1405.2
9.8	87.6	1407.2

The continuous current drain of the receiver, with the threshold switching circuit off, is 5 ma (at 12 v).



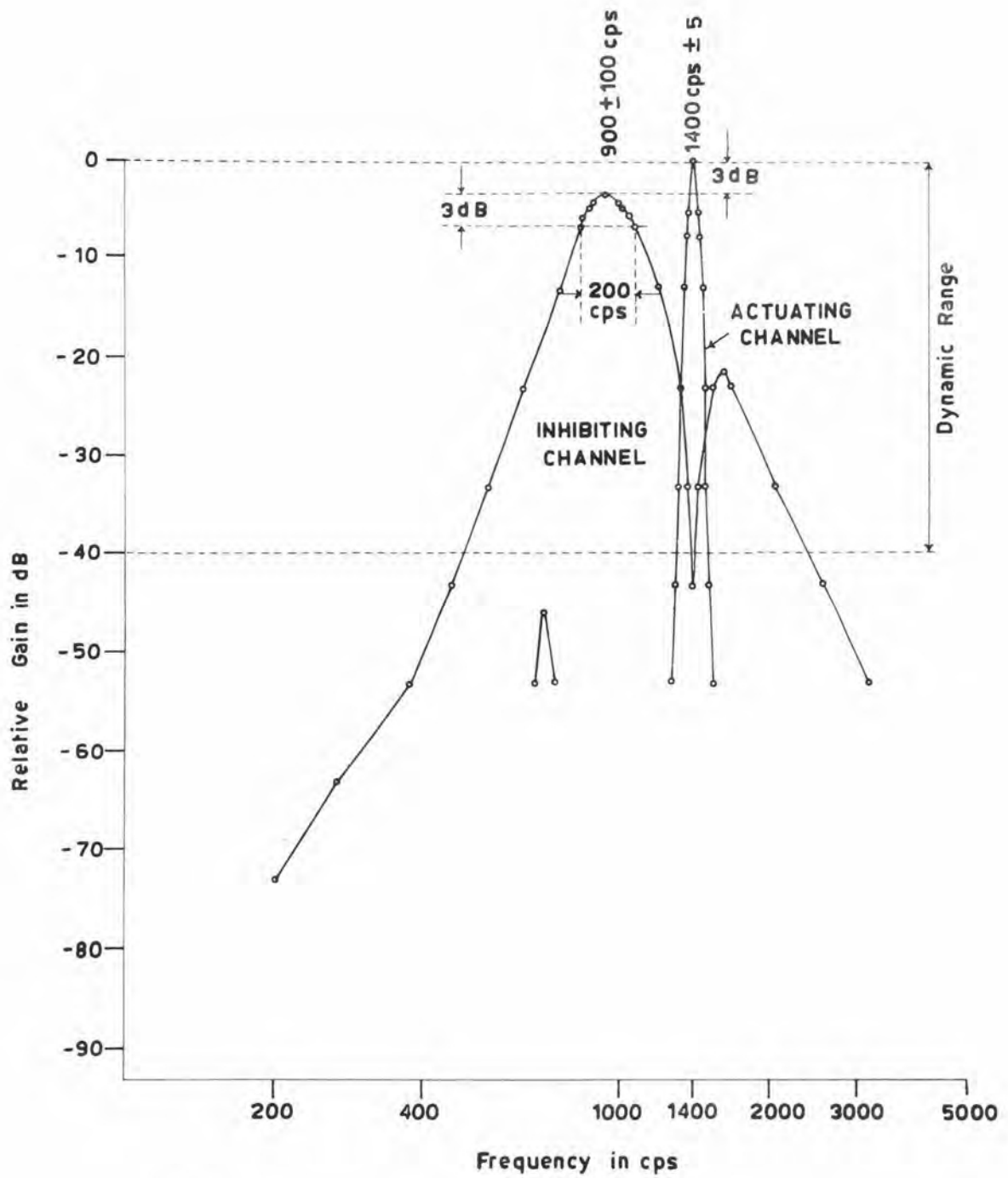
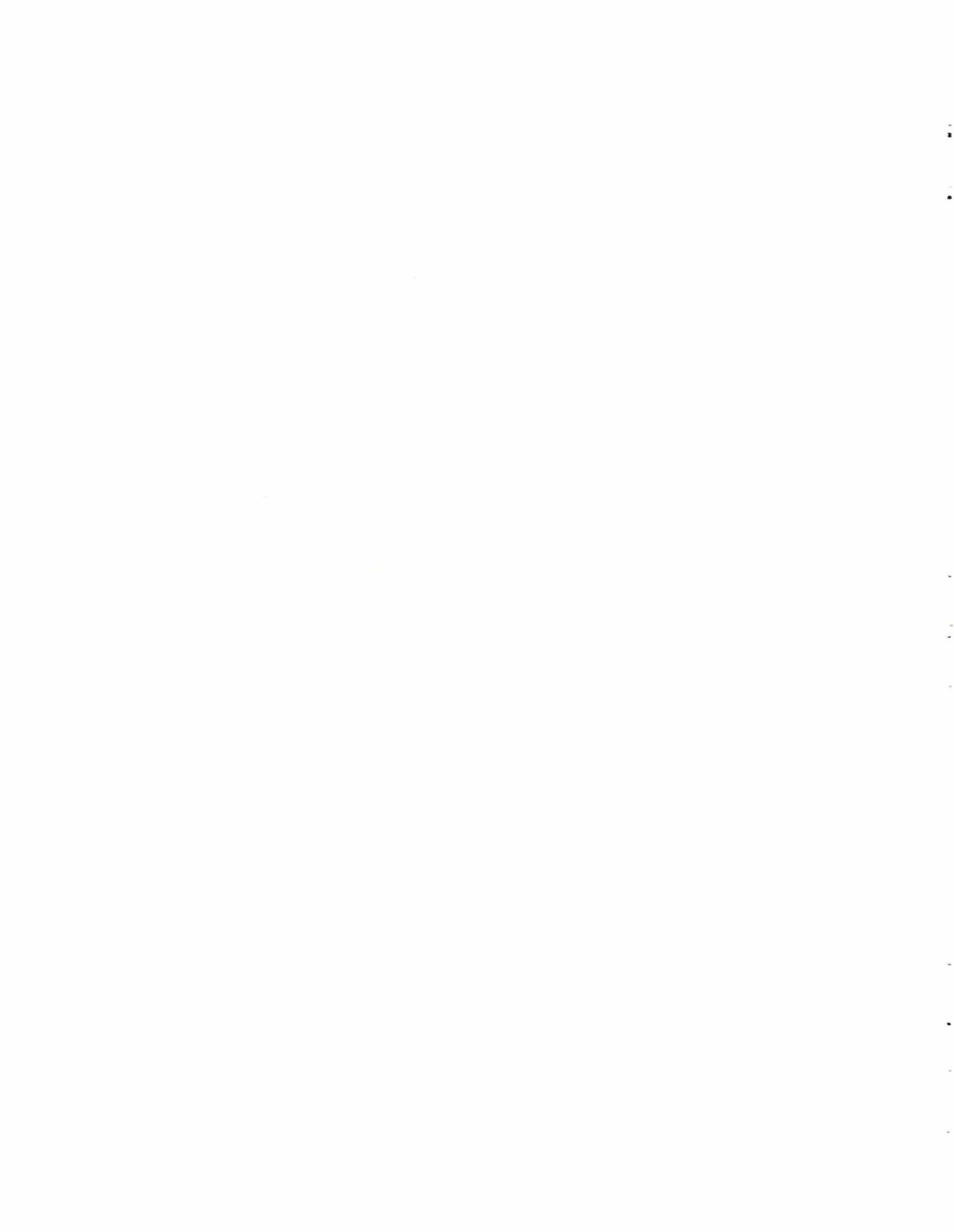

Fig. 7 Frequency Response of the two Receiving Channels



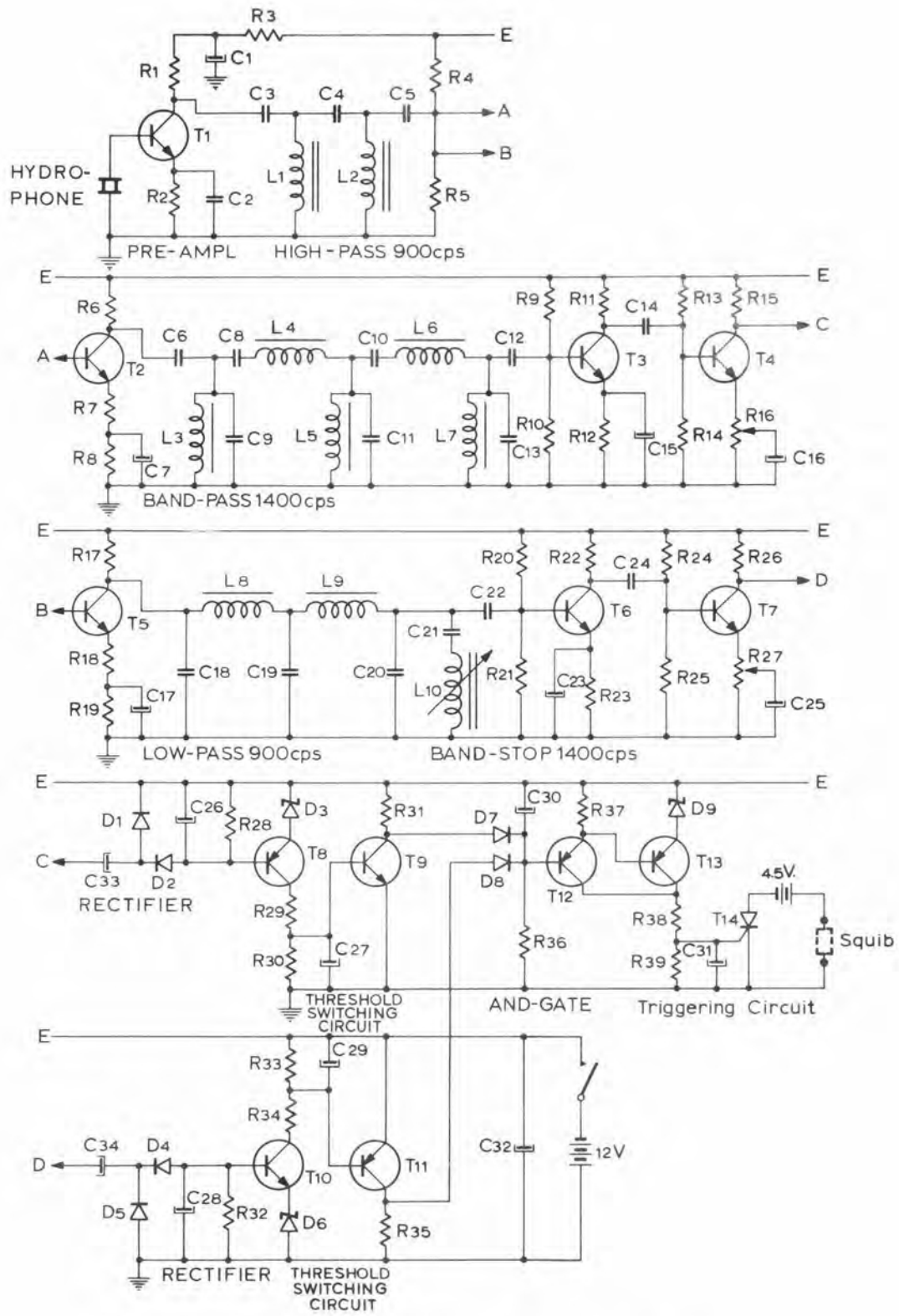
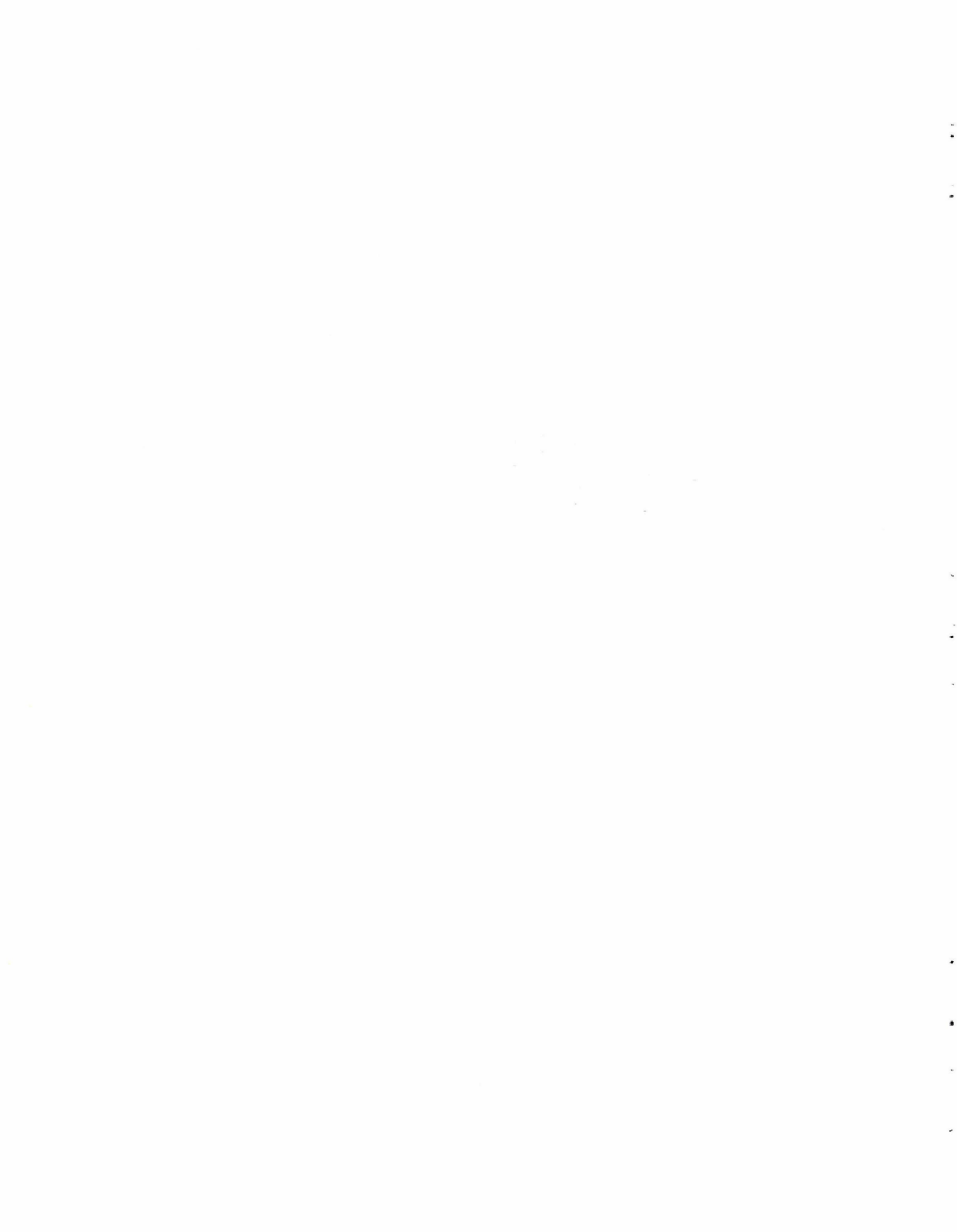

Fig. 8 Electronic Circuit of Receiver

Electronic parts listed in following page

R 1	10 K	
R 2	39 K	
R 3	10 K	
R 4	100 K	
R 5	100 K	
R 6	3.3 K	
R 7	100 Ω	
R 8	4.7 K	
R 9	330 K	
R 10	120 K	
R 11	10 K	
R 12	5.6 K	
R 13	100 K	
R 14	33 K	
R 15	4.7 K	
R 16	2.5 K	
R 17	3.3 K	
R 18	100 Ω	
R 19	4.7 K	
R 20	330 K	
R 21	120 K	
R 22	10 K	
R 23	5.6 K	
R 24	100 K	
R 25	33 K	
R 26	4.7 K	
R 27	2.5 K	
R 28	100 K	
R 29	8.2 K	
R 30	1.5 K	
R 31	4.7 K	
R 32	100 K	
R 33	1.5 K	
R 34	8.2 K	
R 35	4.7 K	
R 36	0.47 M	
R 37	1 M	
R 38	3.3 K	
R 39	3.3 K	
C 1	22 μ F	
C 2	0.3 μ F	
C 3	9.95 μ F	
C 4	4.97 μ F	
C 5	9.95 μ F	
C 6	0.3 μ F	
C 7	22 μ F	
C 8	1230 μ F	
C 9	0.48 μ F	
C 10	1230 ρ F	
C 11	0.96 μ F	
C 12	0.3 μ F	
C 13	0.48 μ F	
C 14	1.5 μ F	
C 15	22 μ F	
C 16	22 μ F	
C 17	22 μ F	
C 18	44 η F	
C 19	87.5 η F	
C 20	44 η F	
C 21	7.8 η F	
C 22	0.3 μ F	
C 23	22 μ F	
C 24	1.5 μ F	
C 25	22 μ F	
C 26	22 μ F	
C 27	22 μ F	
C 28	22 μ F	
C 29	22 μ F	
C 30	47 μ F	
C 31	22 μ F	
C 32	100 μ F	
C 33	22 μ F	
C 34	22 μ F	
T 1	2 N 2645	
T 2	2 N 1711	
T 3	2 N 1711	
T 4	2 N 1711	
T 5	2 N 1711	
T 6	2 N 1711	
T 7	2 N 1711	
T 8	BCZ 11	
T 9	2 N 708	
T 10	2 N 708	
T 11	BCZ 11	
T 12	BCZ 11	
T 13	BCZ 11	
D 1	OA 200	
D 2	OA 200	
D 3	TZ 105	
D 4	OA 200	
D 5	OA 200	
D 6	TZ 105	
D 7	OA 200	
D 8	OA 200	
L 1	995 mH	
L 2	995 mH	
L 3	26 mH	
L 4	10.5 H	
L 5	13 mH	
L 6	10.5 H	
L 7	26 mH	
L 8	1.005 H	
L 9	1.005 H	
L 10	1.7 H	

Electronic parts



5. THE MECHANICAL RELEASER AND THE PRESSURE CONTAINERS

Squib S is a twin explosive latch pin model TL P-2 manufactured by the Conax Corporation. Each primer cap has 0.6 - 1.2 ohm resistance and will fire with a current of 1 amp from a common flashlight battery.

When the squib S (Fig. 9) fires, piston P is projected upward and the twin jaws J release the anchor line head H and let the buoy rise to surface trailing the instrumented cable and the releasing unit. The same latch pin can be used almost indefinitely by changing the explosive caps.

The pressure resistant cases for both the receiver and the mechanical releaser (Figs. 2 and 9) are non-corrosive aluminum tubing AR77 (High Duty Alloy Ltd, England) capable of withstanding a pressure of 400 kg/cm^2 . The two end-plates are sealed with O rings (type P60 and P90) made by the Angst & Phister Co. in synthetic rubber G. A. C. O. for long term use at a maximum static pressure of about 100 kg/cm^2 . For long term application at higher pressures, special O rings are advisable.

The receiver and releaser are mounted coaxially at the head of the anchor line. The load is supported by a stainless steel trapeze which leaves the receiver removable. The load is applied instead to the axis of the releaser and supported by the squib's cylinder. Galvanic corrosive action is prevented by proper insulating material (paint and spacers).

6. CONCLUSIONS

The system, as described, was constructed in the laboratory with available parts and is considered a prototype. The design has been proved at sea and simplification of construction is now in process. This is assisted by the present availability of inexpensive, compact, solid-state filters.

7. ACKNOWLEDGMENTS

Many people from Hudson Laboratories, Woods Hole Oceanographic Institute, and SACLANTCEN have, at different times, contributed advice during the conception of this unit.

Particular thanks are given to Mr. Arne Johansen for reviewing the electronic circuit and the manuscript of the receiver; to Mr. C. Leroy for reviewing the section on acoustical considerations; to Mr. Manzotti for designing the technical parts; to Mr. Menelli for making the actual receiver and to Mr. P. Weber and Hudson Laboratories for furnishing us with the acoustic source.

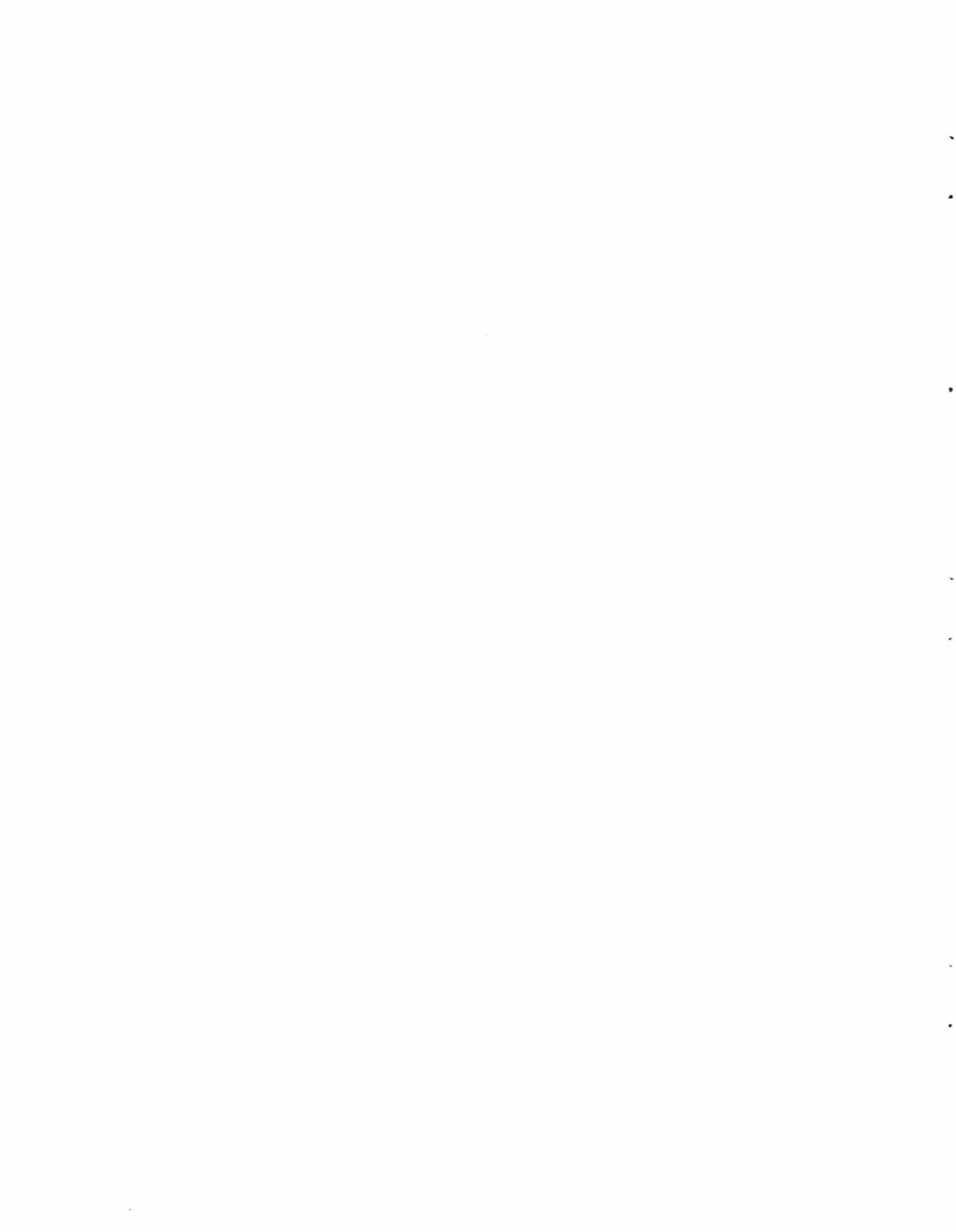

REFERENCES

1. U. S. Department of Commerce, Office of Technical Services, Principles and Applications of Underwater Sound, Vol. 7, 1946.
2. Laboratoire de Détection Sousmarine du Brusc, Aide Mémoire d'Acoustique Sous Marine, 1958.
3. Hudson Laboratories, Hydrophone Development at Hudson Laboratories 1951 to 1958, by Edward T. O'Neill, Technical Report No. 70, 15 February 1959.
4. Hudson Laboratories, WT. 2. Transducer Serial 1300, by Peter Weber, Internal Report, 1960.

Commander Central Mediterranean (COMEDCENT) Naples, Italy	1 copy	NLR United Kingdom British Defence Staffs, Washington 3100 Massachusetts Avenue, N. W. Washington, D. C.	1 copy
Commander Submarine Mediterranean (COMSUBMED) Malta, G. C.	1 copy	NLR United States SACLANT Norfolk 11, Virginia	40 copies
<u>National Liaison Representatives</u>		<u>Scientific Committee of National Representatives</u>	
NLR Belgium Belgian Military Mission 3330 Garfield Street, N. W. Washington, D. C.	1 copy	Dr. J. E. Keyston Defense Research Board Department of National Defense Ottawa, Canada	1 copy
NLR Canada Canadian Joint Staff 2450 Massachusetts Avenue, N. W. Washington, D. C.	1 copy	G. Meunier Ingenieur en Chef des Genie Maritime Services Technique des Constructions et Armes Navales 8 Boulevard Victor Paris 15 ^e , France	1 copy
NLR Denmark Danish Military Mission 3200 Whitehaven Street, N. W. Washington, D. C.	1 copy	Dr. E. Schulze Bundesministerium der Verteidigung ABT H ROMAN 2/3 Bonn, Germany	1 copy
NLR France French Military Mission 1759 "R" Street, N. W. Washington, D. C.	1 copy	Commander A. Pettas Ministry of National Defense Athens, Greece	1 copy
NLR Germany German Military Mission 3215 Cathedral Avenue, N. W. Washington, D. C.	1 copy	Professor Dr. Maurizio Federici c/o MARICOMITARMI Ministero della Marina Rome, Italy	1 copy
NLR Greece Greek Military Mission 2228 Massachusetts Avenue, N. W. Washington, D. C.	1 copy	Dr. M. W. Van Batenburg Fysisch Laboratorium RVO-TNO Waalsdorplakte The Hague, Netherlands	1 copy
NLR Italy Italian Military Mission 3221 Garfield Street, N. W. Washington, D. C.	1 copy	Mr. A. W. Ross Department of Physical Research Admiralty, Whitehall London S. W. 1, England	1 copy
NLR Netherlands Netherlands Joint Staff Mission 1470 Euclid Street, N. W. Washington, D. C.	1 copy	Dr. J. E. Henderson Department of Physics University of Washington Seattle 5, Washington	1 copy
NLR Norway Norwegian Military Mission 2720 34th Street, N. W. Washington, D. C.	1 copy	
NLR Portugal Portuguese Military Mission 2310 Tracy Place, N. W. Washington, D. C.	1 copy	Standing Group, NATO (SGN) Room 2C256, The Pentagon Washington 25, D. C.	3 copies
NLR Turkey Turkish Joint Staff Mission 2125 LeRoy Place, N. W. Washington, D. C.	1 copy	Standing Group Representative (SGREP) Place du Marechal de Lattre de Tassigny Paris 16 ^e , France	5 copies

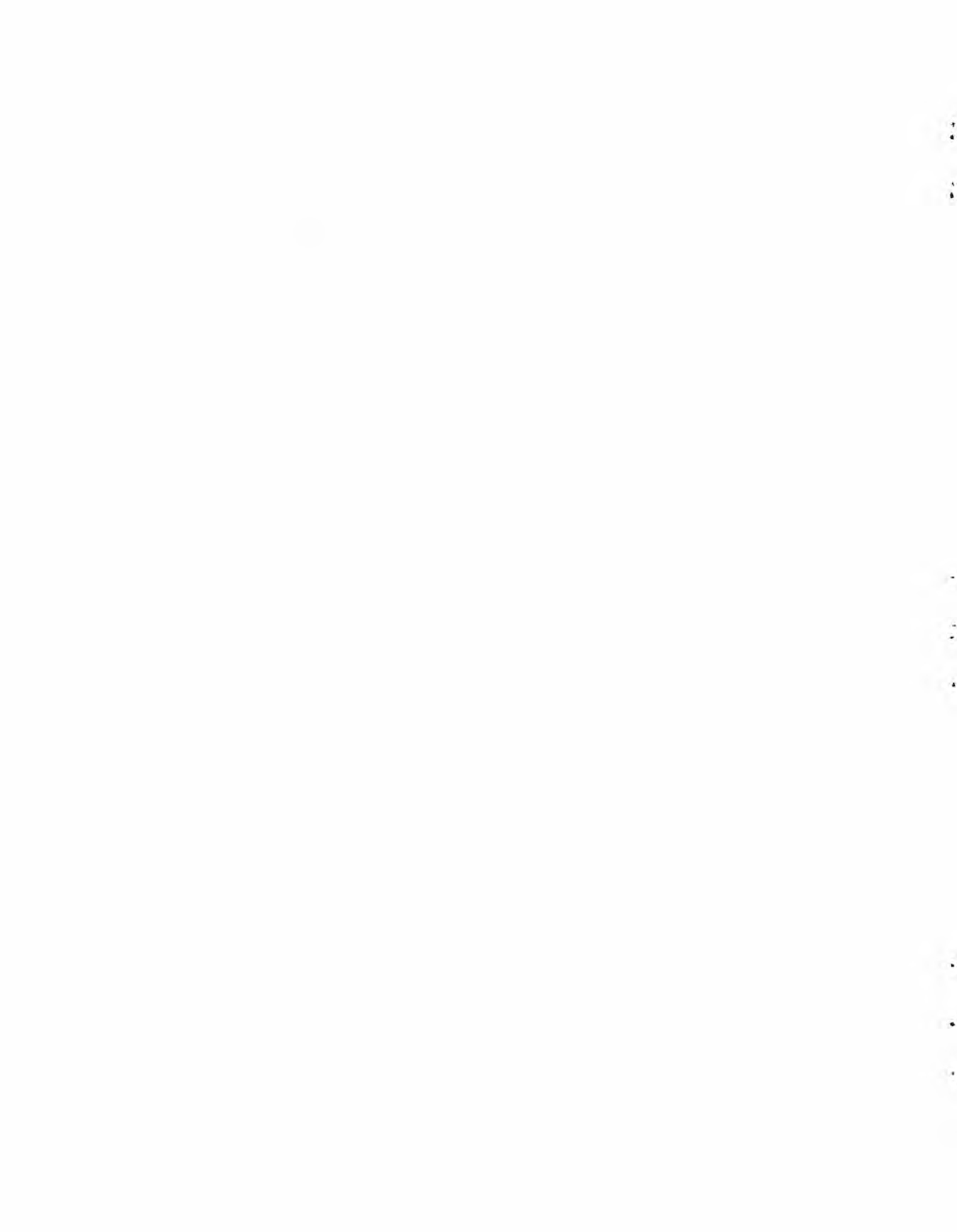



NATO UNCLASSIFIED

NATO UNCLASSIFIED