

SACLANTCEN Memorandum SM - 183

**SACLANT ASW
RESEARCH CENTRE
MEMORANDUM**

SACLANT ASW RESEARCH CENTRE
LIBRARY COPY # 1



**A MICROCOMPUTER-CONTROLLED DIGITAL ACQUISITION
AND ANALYSIS SYSTEM
FOR THE EXPENDABLE BATHYTHERMOGRAPH**

by

Brian WANNAMAKER
Roberto ROSSI
Philip NESFIELD
Paolo SAIA

OCTOBER 1985

NORTH
ATLANTIC
TREATY
ORGANIZATION

SACLANTCEN
LA SPEZIA, ITALY

This document is unclassified. The information it contains is published subject to the conditions of the legend printed on the inside cover. Short quotations from it may be made in other publications if credit is given to the author(s). Except for working copies for research purposes or for use in official NATO publications, reproduction requires the authorization of the Director of SACLANTCEN.

Report no. changed (Mar 2006): SM-183-UU

This document is released to a NATO Government at the direction of the SACLANTCEN subject to the following conditions:

1. The recipient NATO Government agrees to use its best endeavours to ensure that the information herein disclosed, whether or not it bears a security classification, is not dealt with in any manner (a) contrary to the intent of the provisions of the Charter of the Centre, or (b) prejudicial to the rights of the owner thereof to obtain patent, copyright, or other like statutory protection therefor.

2. If the technical information was originally released to the Centre by a NATO Government subject to restrictions clearly marked on this document the recipient NATO Government agrees to use its best endeavours to abide by the terms of the restrictions so imposed by the releasing Government.

Published by



SACLANTCEN SM-183

NORTH ATLANTIC TREATY ORGANIZATION

SACLANT ASW Research Centre
Viale San Bartolomeo 400,
I-19026 San Bartolomeo (SP), Italy.

tel: national 0187 540111
international + 39 187 540111

telex: 271148 SACENT I

A MICROCOMPUTER-CONTROLLED DIGITAL ACQUISITION
AND ANALYSIS SYSTEM
FOR THE EXPENDABLE BATHYTHERMOGRAPH

by

Brian Wannamaker
Roberto Rossi
Philip Nesfield
Paolo Saia

October 1985

This memorandum has been prepared within the SACLANTCEN
Underwater Research Division as part of Project 01.

R. Thiele

R. THIELE
Division Chief

Report no. changed (Mar 2006): SM-183-UU

TABLE OF CONTENTS

	<u>Page</u>
ABSTRACT	1
INTRODUCTION	1
1 OPERATION AS A SYSTEM	3
2 HARDWARE	5
2.1 The Self Test Circuit	5
2.2 Resistance to Voltage Converter	6
2.3 Analogue to Digital Conversion	7
2.4 HP-IB Processor and Control Logic	7
2.5 Sample Sequencer	7
2.6 Test Feature	7
2.7 Accuracy	8
2.8 Navigation Satellite Interface	9
3 SOFTWARE	9
SUMMARY	15
REFERENCES	15

List of Figures

1. Expendable bathythermograph (XBT) acquisition and analysis system.	4
2. Computer monitor showing the eight special function keys.	4
3. Block diagram of the XBT controller interface.	6
4. Equivalent measurement circuit of the interface.	6
5. Simulated test profile.	8
6. Output resistance of controller interface vs voltage output of measurement amplifier.	8
7. XBT resistance measuring error.	9
8. XBT plots and radio message format.	12
9. Sequential plots of XBT profiles.	13
10. Sample plots of temperature profiles.	14

Report no. changed (Mar 2006): SM-183-UU

A MICROCOMPUTER-CONTROLLED DIGITAL ACQUISITION AND ANALYSIS SYSTEM
FOR THE EXPENDABLE BATHYTHERMOGRAPH

by

Brian Wannamaker, Roberto Rossi, Philip Nesfield and Paolo Saia

ABSTRACT

For a number of years the expendable bathythermograph (XBT) has been an important tool for basic and applied oceanographic survey work. This has led to a significant body of work being done on the accuracy of the XBT system as a whole. One of the most important limitations has been the analogue recording and manual digitisation of the profiles. A digital interface is described that replaces the standard deck unit and removes this problem. The interface is controlled through an IEEE-488 interface bus by a microcomputer or a minicomputer. The data is stored with 12 bit precision 10 times a second. As many as 115 profiles, each recording to 450 m in depth, may be stored on a single cassette. The microcomputer and plotter may be used for a number of analytical tasks including isotherm following, contour plotting, and sound speed or density calculations. The profiles may also be automatically compressed by a "most reversible" algorithm and coded to standard format for radio transmission. The bibliography contains presently available research reports on the XBT.

INTRODUCTION

The expendable bathythermograph (XBT) was initially developed to quickly determine the thermal structure of the upper ocean from a ship without hampering normal operations. It replaced the mechanical bathythermograph (BT) which, like present salinity-temperature-depth (STD) and conductivity-temperature-depth (CTD) profilers, required the ship to heave to during lowering or raising of the XBT. The resulting thermal profile was used for sonar performance predictions.

As oceanographers became increasingly aware of the horizontal and temporal variability in the oceans from scattered STD casts, they realized the value of the XBT for quick, dense profiling to record this variability. Thus the XBT was used to fill in the gaps in STD surveys. The acoustic community also realized the possible significance of oceanic variability on sound propagation. At the same time the availability of increased computing power and sophistication of acoustic models meant that high resolution range dependent data could be used if available. For these reasons there was an increasing number of studies of the accuracy and reliability of the XBT system, especially as the MODE (Mid Ocean Dynamics Experiment) and POLYMODE experiments in the early 70's.

Report no. changed (Mar 2006): SM-183-UU

These studies compared BT results of nearly simultaneous STD and CTD casts. Because the experimenters were interested in retrieving dynamic heights from the data the intercomparison results were usually processed as differences in the depth of the appearance of specific isotherms.

The BTs themselves have no pressure sensors; depth is calculated as a function of the time since the BT entered the water. The coefficients of this function are supplied by the manufacturer. Any error in temperature measurement or in these coefficients will change the apparent depth of an isotherm.

Georgi et al [1], using direct calibrations of four hundred BTs, suggested that the XBT probe-to-probe variability would be less than $\pm 0.06^{\circ}\text{C}$ at the 95% confidence level if the Sippican analogue recorder is not used. The standard deviation is less than 0.03°C at 0°C and decreases to less than 0.01°C in the region of 25 to 30°C . This decrease with temperature is attributable to matching of the individual thermistors at 25°C during manufacture. Thus temperature errors in the XBTs are well behaved and can be translated into an error in isotherm depth by considering the local temperature gradient.

MODE and POLYMODE researchers generally used the deep T5 (1800 m) and T7 (750 m) probes. References [2,3,4] supplied evidence of errors in the depth coefficients suggested by the manufacturer. Seaver and Kuleshov [5] were reasonably successful in modelling this error and ascribed it to the inverse relationship between kinematic viscosity and temperature and the related changes in pressure drag on the falling probe. They suggested that weight variations between probes due to air entrapped with the wire should result in depth errors with a standard deviation of only 1.6 m at 750m. On the other hand changes in surface roughness on the BT nose section sufficient to vary the point of transition of laminar turbulent flow from the nose of the probe to the point of maximum cross-sectional area would create a standard deviation in apparent isotherm depth of 6.2 m at 750 m.

A statistical analysis of nearly two thousand T4 XBTs launched and recorded by U.S. Navy ships has been reported by Anderson [6]. Only 80% of the temperature profiles from these casts were visually acceptable and 40% of a subset of 518 casts met the accuracy criteria he set. In commenting on Anderson's report, the manufacturer, Sippican, suggested that many of the failures may have been due to aging of the probes beyond the two year warranty period. This period is set by the time needed to degrade the insulation on the wire and thermistor. A Netherlands Navy study reported that the signal wire becomes sticky because of age and high temperatures. This stickiness leads to increased tension wire stretch, depth errors and spikes on the temperature depth record during deployment (report of the 9th MILOC meeting). Sippican states that they will provide replacement units if there is an abnormally high failure rate beyond 10%. A review of the errors commonly found with the standard XBT system is given by Kronen and Blumenthal [7].

It became clear to many researchers that much of the error in XBT records were the result of the standard deck unit and analogue recorder and the manual digitisation. A study of two US Navy exercises showed that more than 60% of the BTs collected were improperly encoded [8]. This deficiency

Report no. changed (Mar 2006): SM-183-UU

could be avoided by digitally recording the data. The manufacturer has for some years offered a digital shaft encoder or retransmitting potentiometer mounted on the analogue recorder temperature servoassembly. A system at SACLANTCEN used the encoder for its first digital interface [9]. This was successful in alleviating time consuming and error prone pre-analysis procedures but was limited in precision to 0.05° because of the encoding system. The potentiometer was used as part of a system by McDowell and Dorson [3] along with a 12 bit analogue-to-digital converter and cassette recorder. This was the basis of a commercial system by Bathy Systems Inc.

Both systems were constrained by the limits of the signal processing before the digitisation. Other systems were built to completely replace the standard on-deck electronics (e.g. [10]) and some were controlled by microprocessors [11]. In 1985 Sippican has also announced a digital interface (MK-9) with attached microcomputer (HP-85) although this system records only one XBT profile per cassette.

A specific system to collect temperature gradient measurements along with temperature measurements has been developed by Lange and Johnson [12]. It replaces the XBT with a recoverable instrument package for rapid profiling that is being developed at the University of Washington [13].

This memorandum discusses a microcomputer controlled deck unit system developed at SACLANTCEN. As yet it has not been compared to other systems of the same concept. From the available literature it appears that the SACLANTCEN system offers greater data storage than some, easier one-person use and more complete internal self-checking and flexibility than others.

The first section of this report will outline the use of this system as a complete unit. This will be followed by more detail about the hardware and software. References concerning XBTs have been extracted from a computerized bibliography accessible on the SACLANTCEN main frame computer and is provided at the end of this memorandum.

1 OPERATION AS A SYSTEM.

The components of the XBT acquisition and analysis system are shown in Fig. 1.

The controller interface (C/I) completely replaces the normal deck unit; the cable from the launcher to the normal unit is simply disconnected and reconnected to the new controller interface (C/I) by the same type of amphenol connector. (This is especially important to take advantage of ships of opportunity. One of the units has already been used aboard the Italian Navy hydrographic ship MAGNAGHI (IT) in 1984.) Hand launchers may be connected via a rear terminal strip. The C/I is in turn controlled by a micro- or mini-computer.

One person can use the system if necessary; communication with an assistant at the launcher is not needed. When the acquisition program runs, the

Report no. changed (Mar 2006): SM-183-UU

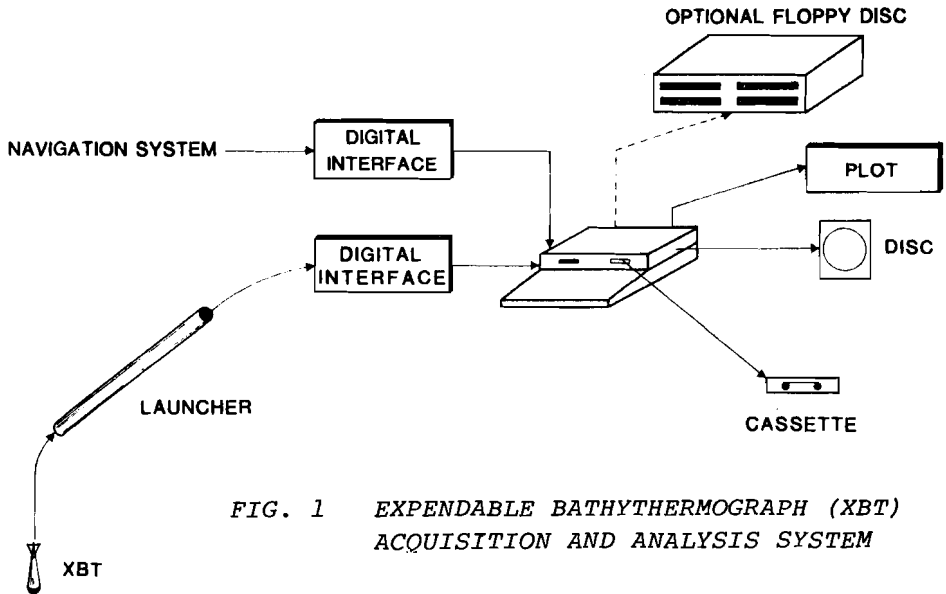

FIG. 1 EXPENSIBLE BATHYTHERMOGRAPH (XBT) ACQUISITION AND ANALYSIS SYSTEM

operator, when asked, reads the real time to form part of the header record of each data file.

The labels of the eight special function keys are displayed along the bottom of the computer monitor as shown in Fig. 2. These keys, always active, are programmable to transfer program execution to numbered subroutines. For example "UNIT" initialises the output plot parameters. The operator is also asked for the BT type since the fall rate of the probe and data file size required are type-dependent. These values are then available for use in the routines until the program is halted. When the parameters have been initialized the operator presses "GO" and the CRT prompts "PLEASE RELOAD" (the XBT launcher).

If working alone the operator can now go to the launcher and load and launch the BT; internal checks and data measurement are automatic. The system could be set in a loop to prepare immediately for another BT while the operator remained at the launcher. The data is plotted on the computer monitor during acquisition. The conversion from probe-thermistor resistance to temperature is through the polynomial.

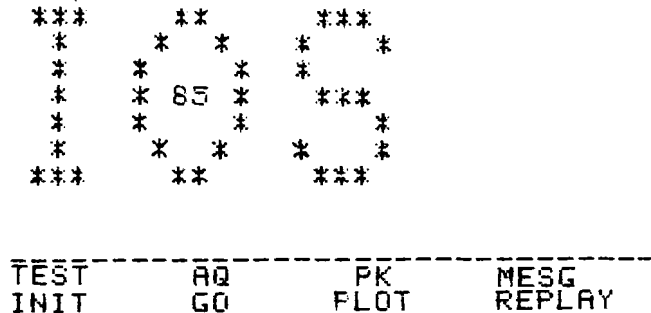

FIG. 2 COMPUTER MONITOR SHOWING THE EIGHT SPECIAL FUNCTION KEYS

Report no. changed (Mar 2006): SM-183-UU

$$T = 63.2204 - 11.9493R + 1.10525 R^2 - 0.0552171 R^3 + 0.0010914 R^4$$

which was fitted to the calibration data supplied by the manufacturer.

Temperature is in degrees Celsius ($^{\circ}\text{C}$) and resistance is in $\text{k}\Omega$. The depth calculation is done with the formula:

$$D = (6.472 - 0.00216 * J/10) * J/10$$

for T4, T7 and T2 type XBT's and

$$D = (6.828 - 0.00182 * J/10) * J/10$$

for T5 units

with D the depth in metres and J the sample number (1 sample is equivalent to 0.1 s) since entering the sea.

Wire breakage during the acquisition is reported by the C/I status word.

The data from forty-two T4 BTs will fit on one DC 100A data cassette. This is a computer operating system limit and could increase with software changes to 115 profiles.

2 HARDWARE

The Controller Interface (C/I) replaces the standard Sippican desk unit and is transportable, weighing only about 9 kg. The case can be mounted in a rack.

The standard deck launcher or hand launcher may be connected either via a 8 pin amphenol connector or a terminal strip.

The microcomputer and XBT C/I are linked by an IEEE-488 or GP-IB (General Purpose Interface Bus) also referred to as HP-IB. A wide range of micro and mini computers can thus be used. However, SACLANTCEN uses an HP-85 micro-computer or HP 21MX series mini-computer.

The computer sends control words to the C/I via this link and can request status reports from it as well as data. The C/I also displays its own status and that of the HP-IB as well as the probe type in use via front panel light emitting diodes (LEDs).

A simplified block diagram of the C/I circuit is shown in Fig. 3.

2.1 The Self Test Circuit

This circuit checks the launcher, probe and launcher-to-C/I cable each time the breach of the launcher is opened and closed.

The circuit tests for certain voltage thresholds above which the probe and connections are indicated to be good. If this test is completed the input

Report no. changed (Mar 2006): SM-183-UU

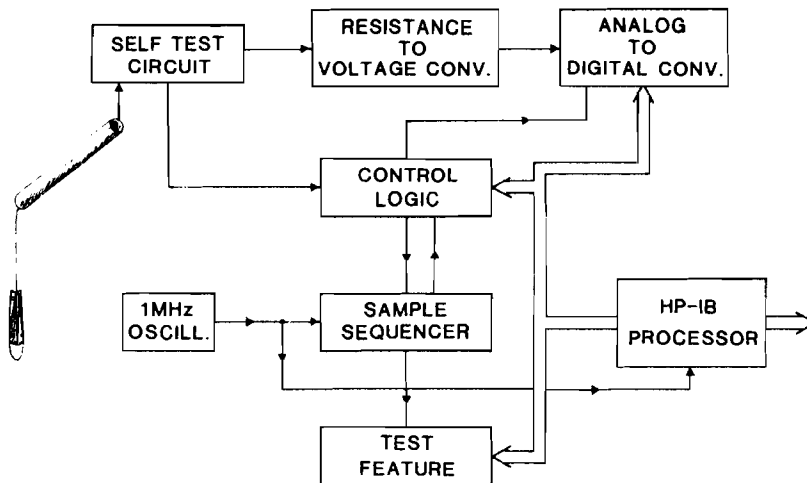

FIG. 3 BLOCK DIAGRAM OF THE XBT CONTROLLER INTERFACE

terminals of the C/I are connected across a 10 k Ω precision resistor. Data are sent to the host for 1 second, enough time for 100 samples, and are checked for a temperature of $9.92 \pm 0.01^\circ\text{C}$. (This temperature indicates that the analogue interface is working properly. Any difference from this value represents a bias that is correctable later during the data analysis). The host computer can then send a control word to enable the launch.

2.2 Resistance to Voltage Converter

After the completion of the check and the receipt of an "ENABLE" command the probe is connected to the input of the resistance-to-voltage converter shown in Fig. 4.

This portion of the C/I is as described in Stegen et al [10]. The probe thermistor forms one leg of a self-balancing bridge circuit. The bridge is formed by the thermistor, two precision resistors and J-FET T1. The resistance of T1 is constrained to equal the thermistor resistance by the feed back of operational amplifier A1. Differential amplifier A2 provides an output voltage directly proportional to the resistance of T1 and thus of the probe thermistor.

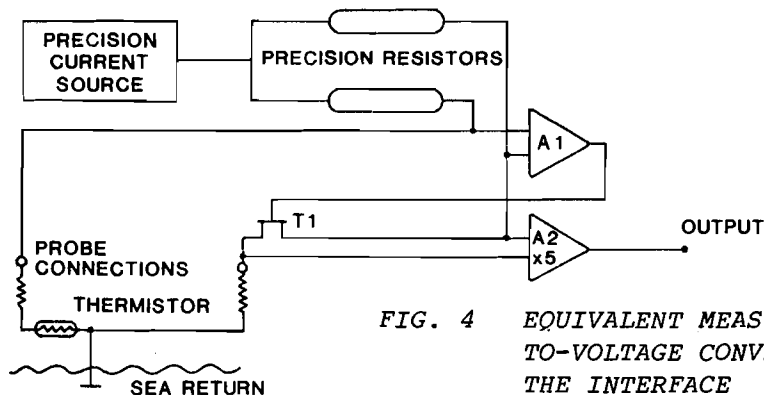

FIG. 4 EQUIVALENT MEASUREMENT (RESISTANCE-TO-VOLTAGE CONVERTER) CIRCUIT OF THE INTERFACE

Report no. changed (Mar 2006): SM-183-UU

2.3 Analogue to Digital Conversion

The analogue output of A2 is fed to the input of a 14 bit analogue to digital converter. The most significant 12 bits about the output of a cyclic 4 bit counter thus creating the 16 bit data word that is sent to the computer. The data conversion is completed in 100 ms to an accuracy of $\pm 0.005\%$.

The counter is triggered to zero by the closing of the sensor circuit by the sea path when the probe enters the water. This counter is used as a diagnostic tool to determine that no data samples are being lost between the C/I and host computer.

2.4 HP-IB Processor and Control Logic

The HP-IB processor is a single LSI monolithic chip handling all the data flow in both directions between the host computer and the XBT C/I using the standard IEEE-488 (HP-IB) protocol. The associated control logic insures that all handshaking signals from and to the HP-IB processor are handled properly.

2.5 Sample Sequencer

The sample sequencer supplies the analogue to digital trigger signals at a frequency of 10 Hz derived by electronically dividing the output of a precision 1 MHz crystal oscillator. This circuit also controls the generation of the self test digital data and the four bit counter. Eventually, the system will incorporate the ability to change sampling rate under host control.

2.6 Test Feature

The test feature allows a check to be made of the C/I itself and also generates data for the checking of the computer acquisition and processing.

There are three different tests:

- a) Profile simulation: this test generates 256 samples that simulate a resistance change (ranging from 3261.7 to 18090.8 ohms or 34.211°C to -1.253°C). The resulting profile is shown in Fig. 5.
- b) Minimum resistance value: this test produces an output of 3261.7 ohms (34.211°).
- c) Maximum resistance value: this test produces an output of 18090.8 Ω (-1.253°C).

In each case the test is programmed by the host computer and initiated by depressing the 'TEST' push button on the front panel.

Report no. changed (Mar 2006): SM-183-UU

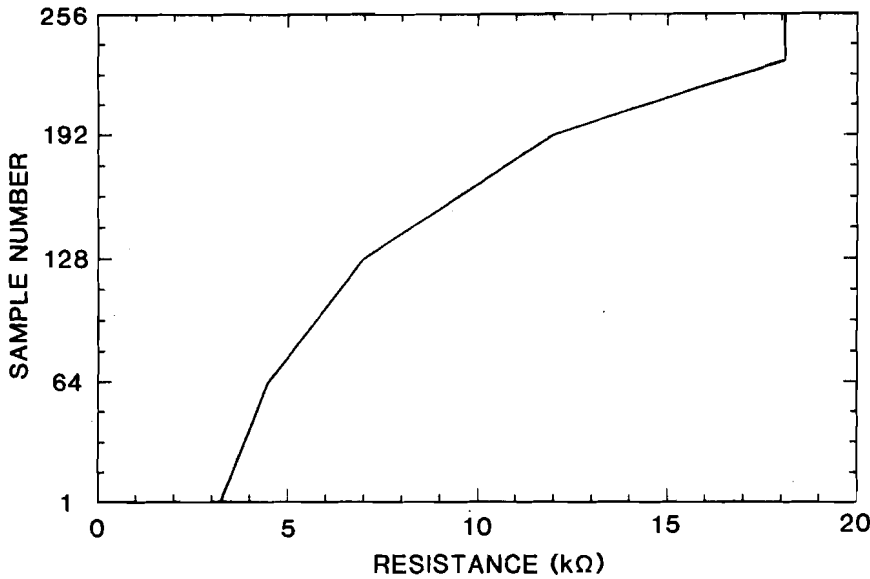

FIG. 5
SIMULATED TEST
PROFILE

2.7 Accuracy

Figure 6 is a plot of the output resistance value of the controller/ interface measured by the micro-computer vs the voltage output of amplifier A2 (see Fig. 4). This line is linear with a variation equal to ± 1 bit of the analogue/digital (A/D) converter.

Figure 7 is the result of an attempt to measure the absolute accuracy of the C/I. The XBT probe was replaced with a resistor decade box (which has a precision of 0.5%). The difference between the output resistance value and the decade value is plotted over the full range of the output of amplifier A2. However, at the bottom of the scale the 'error' is less than the uncertainty in the input value.

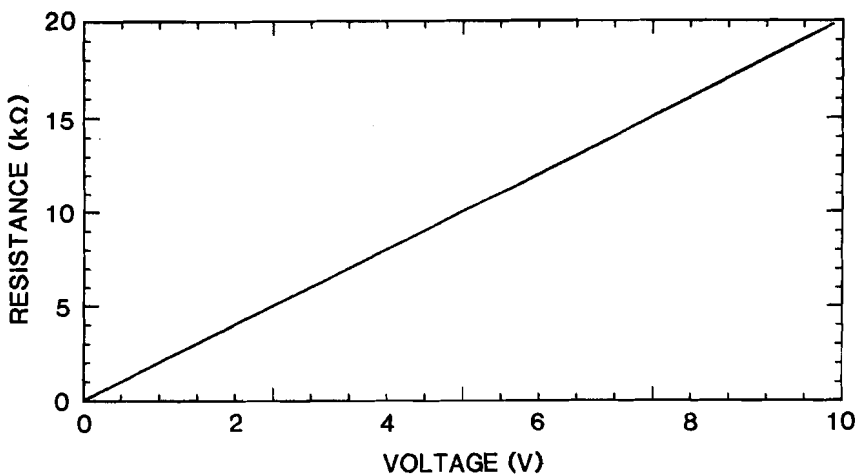

FIG. 6
OUTPUT RESISTANCE
OF CONTROLLER
INTERFACE VS
VOLTAGE OUTPUT OF
MEASUREMENT
AMPLIFIER

Report no. changed (Mar 2006): SM-183-UU

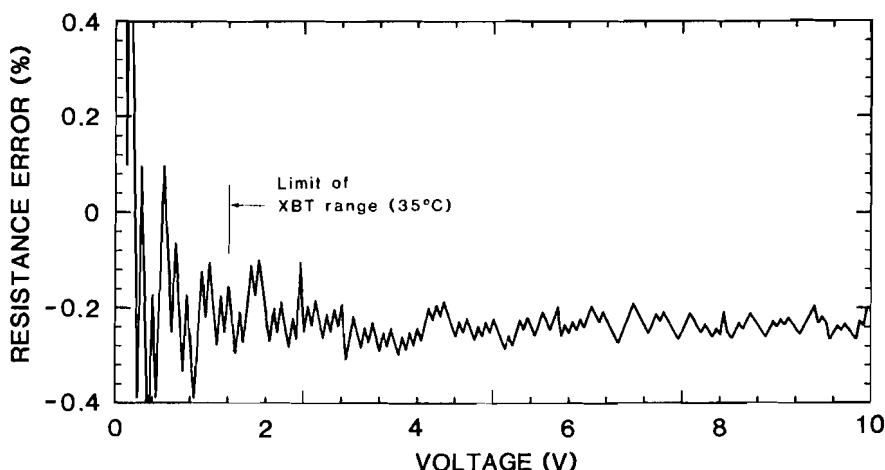

FIG. 7 XBT RESISTANCE MEASURING ERROR
The absolute accuracy of the controller interface is greater than that of the standard

2.8 Navigation Satellite Interface

The SACLANTCEN research ship MARIA PAOLINA G. is equipped for satellite and Loran-C navigation. The computer controlling this can be linked to the HP-85 through an interface built at the Centre. Thus the accurate time and geographical coordinates can be included in each XBT data file. This interface will be discussed elsewhere in connection with a microcomputer system that collects meteorological data.

3 SOFTWARE

The flexibility of the HP-IB interface bus and of the HP-85 microcomputer has made the programming of the data acquisition relatively easy. Acquisition routines for the HP21-MX mini computer series have also been written to incorporate the XBT data into the Integrated Oceanographic System (IOS). The microcomputer allows a more general use of the advantages of the new interface since it is independent of the 110V generators and other computer processing aboard ship.

The basic HP85 includes 16Kbytes (14 576 are available) of read/write memory with an internal operating system running on an expanded version of ANSI BASIC, an integral cassette drive, a CRT screen and a thermal printer. The HP85 used in the XBT system has been expanded with plug-in units for an additional 16K of memory and for external printing and plotting, input/output, matrix functions and mass storage. However the matrix and mass storage functions are not presently required for the data acquisition or analysis.

Two separate routines have been developed; the first is used for data acquisition and single profiles and the second is concerned with stored data.

The first, besides acquiring the profile, can run interface checks, plot the profile (as acquired or from tape), compress the data and print the profile in a standard format, as determined by the operator.

Report no. changed (Mar 2006): SM-183-UU

Flags (variables with value 1 or 0) control optional program branching that is generally held constant for a run. This includes such things as automatic hardcopy of profile, type of surface corrections etc. These values are read from data statements; in BASIC they can be quickly changed by the operator.

Because of the small size of the computer, efforts were made to save storage space which was shared by program and data. The memory requirements for array variables in the HP85 are shown below in Table 1.

TABLE 1
Memory Requirements, HP-85

<u>Type of Array Variable</u>	<u>Bytes of Memory</u>
Full Precision	8 + 8/element
Short Precision	8 + 4/element
Integer	8 + 3/element
String	8 + 1/element

Depth information is not stored. It depends only on BT type and sample number. The BT type is kept as part of the file name and used to branch to the appropriate depth calculation during analysis. Although not a problem so far, loss of data by deficiencies in the system can be determined by following the consecutive counter. The data arrive at the microcomputer as 16 bit integer values that represent an unscaled resistance. Without any loss of accuracy this can be converted to a pair of characters, 8 bits at a time.

Tape files are created just before data acquisition because there is no quick way to determine if an existing data file is full or empty. Storing resistance values rather than calculated temperatures is consistent with the policy of the SACLANTCEN Applied Oceanographic Group to keep raw data, or data that can be unambiguously reconverted to that form. In this case the resistance to temperature conversion is non-linear. However, if this relationship was later found to be in error or if an improved expression was determined, temperatures already converted could not be corrected whereas the raw data would still be available for conversion.

Once the program is running the HP-85 becomes a dedicated computer. To prevent inadvertent program halts the keyboard becomes inactive except for certain specific keys.

The flexibility of the software control and HP-IB allows the correction of other possible errors. These errors include initiating acquisition with "GO" twice or opening the launcher breach between loading and pulling the releasing pin of the probe.

Report no. changed (Mar 2006): SM-183-UU

The data transfer is done in pieces and interrupts other executing tasks. However no data are lost if incoming information is converted and plotted as a temperature vs depth profile during acquisition. The internal screen has a horizontal/vertical resolution of 256×192 dots and the data are scaled between the limits set during the initialisation (INIT) phase. A portion of a profile may be shown at full resolution or a piece of it may be displayed on an external plotter, also connected through an HP-IB link.

A T-4 BT operating for 90 s supplies about 900 temperature data points. Many of these data are redundant, especially those in the surface mixed layer and in the generally isothermal deep layers. The SACLANTCEN data base has a system limit of 125 temperature depth pairs; ships reporting temperature profiles to forecast centres by radio are limited to 20 data pairs in a specified format. Obviously some way to compress the data is necessary.

This may be done by someone reading selected values from the trace or through the use of a digitising table, both procedures are tedious and thus error-prone. Also the digitising must properly take into account the non-linearity of the chart scaling. In any case the manufacturer attributes half of the limit of the system uncertainty of 0.2° to the analogue chart.

The system described here uses a method developed by R. Winterburn and Wannamaker [14]. This algorithm aims to determine a reduced set of temperature, depth pairs that when joined with straight lines will reconstruct the input profile within a known limit.

Basically the algorithm chooses as significant points those at which the change in temperature gradient is above a set threshold. If so the point is kept as a significant point for the reconstruction of the profile; if not it is subjected to the following test: the true value at the midpoint between this point and the last significant point is checked to determine if it is within a preset limit of the straight line joining these significant points. If not, the midpoint becomes significant as well. The international standard for the exchange of oceanographic data IOC [15] states that for XBT data:

" ... flexure points (should be) determined in such a way that linear interpretations fall within $\pm 0.2^\circ\text{C}$ of the original record"

Winterburn and Wannamaker [14] discussed this method for 200 profiles from the Alboran Sea and Gulf of Cadiz in frontal regions. In the Gulf of Cadiz region the profiles show a sudden increase in temperature with depth when the probe entered the Mediterranean outflow. He found that a threshold value of $0.035^\circ\text{C}/\text{m}$ for the gradient change reduced the original number of points of the profiles by 85%. A check against the original data at each original depth value showed an average standard deviation of 0.022°C and maximum error of 0.17°C .

Although a threshold value of $0.3^\circ\text{C}/\text{m}$ was required to reduce each of 15 Alboran Sea profiles to less than 20 points on the HP 85, the error, when compared with the original profile, was generally less than 0.2°C .

Surface temperature measurements present another aspect of the XBT. Results calculated from modelling the time response of the sensor have

Report no. changed (Mar 2006): SM-183-UU

shown that an XBT cannot give an accurate temperature reading until about 4 m depth [16]. Stegen et al [10] suggest ignoring the data during the first four time constants. However, some researchers have found good comparisons with simultaneous measurements by other instruments [17]. In the present system the user may opt through flag setting to ignore the upper 3.7 m reported by the XBT or to extrapolate back up to the surface using the slope between 6 and 4 m [16].

The resulting reduced profile may then be automatically coded into standard radio message format described by Fisher [18]. The depth values are rounded off to the nearest metre and the temperature to tenths of a degree as part of the coding.

An example profile, packed profile and message are shown in Fig. 8. At least one other compression algorithm is in use for XBT data [see Mesecar and Wagner, [11]. Other data compression schemes exist and research is continuing to determine the one most suitable for this application.

A reduced data base of T-S diagrams, although not implemented in the system, is suggested for future development. Mean, median or some other representation of the T-S relationship in a geographical area at a given time of year could be stored on a floppy disk with the appropriate hardware expansion. Flierl and Robinson [19] have suggested an interpolation scheme with a number of T-S curves rather than one representative curve. Over limited regions or within limited periods or if polynomial approximations for the relations were used the T-S curves might fit in the computer memory along with the program. These data bases would allow more accurate estimates of the salinity profile and thus density, sound velocity and geostrophic currents. A data set of mean T-S diagrams has been developed for 5° latitude/longitude squares for the N. Atlantic and Pacific [20]. One for the Mediterranean could be determined from the SMODS data base at SACLANTCEN [21]. A non-regular grid is suggested so that separate files would exist for inside/outside the Alboran Sea gyre for example. Such processing has been done with BT data but usually only after the cruise.

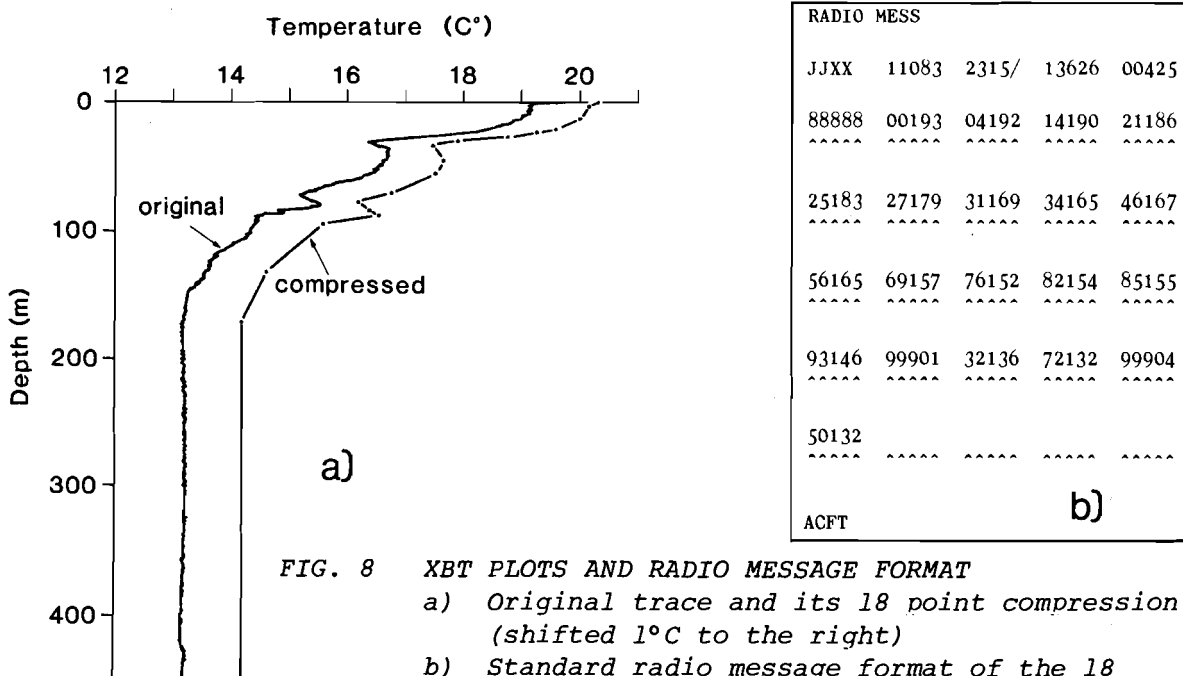

FIG. 8 XBT PLOTS AND RADIO MESSAGE FORMAT
 a) Original trace and its 18 point compression (shifted 1°C to the right)
 b) Standard radio message format of the 18 point compression profile

Report no. changed (Mar 2006): SM-183-UU

Once a series of XBT profiles are on tape they may be processed quickly in sequence. Assuming they are all from the same BT type a depth array can be filled once and retained for use in the second basic software routine. Corresponding temperatures are calculated for each data file upon reading and stored as short precision values (See Table 1).

One type of sequential processing is sequential plotting (see Fig. 9). Another is contour plotting; however, this process may be too complex to be efficient on a machine of this size. The basic problem is the decision process required to join contours through temperature inversions where the same isotherm occurs more than once on some but not all sequential profiles. For the present system this is left to human decision. The system plots the depth of each isotherm with specific symbols. The user need enter only the contour interval, D. Isotherm determination is made easier with the intrinsic integer, sign and logical evaluation routines inherent in the HP85. If two sequential data points are (T1, P1) and (T2, P2) then the number of isotherms between them is

$$\text{INT} \left(\frac{T_1}{D} \right) - \text{INT} \left(\frac{T_2}{D} \right) \quad (\text{Eq. 4})$$

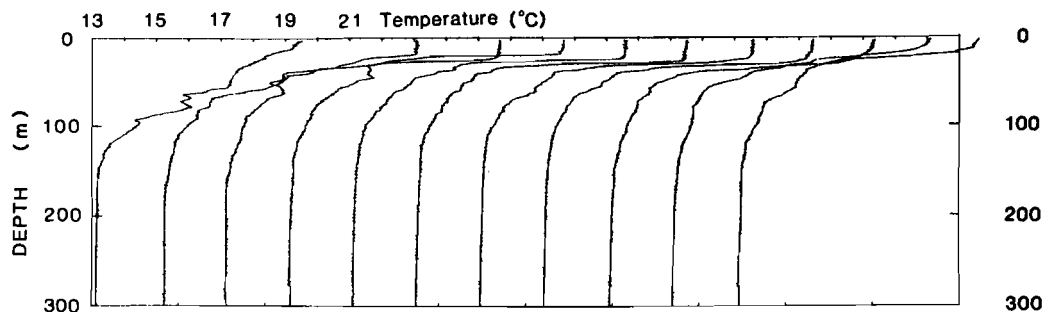

FIG. 9 SEQUENTIAL PLOTS OF XBT PROFILES
(offset by 2°C)

The isotherms can be determined by linear interpolation through a loop.

The first isotherm of the loop is

$$\text{INT} \left((T_1 - B1/C1 + \underline{((T_2 - T_1) > 0)}) * C1 \right)$$

The underlined expression is 1 when true and 0 when false. B1 is a bias used to reduce the number of symbols required. For the Mediterranean it is set equal to 13°C. The direction of the loop is set by the sign of (T2-T1).

Each isotherm has its own distinctive symbol that is stored in a character string and can be treated as a one-dimensional array. The correct symbol can then be retrieved for plotting by determining the appropriate index. The symbols used are limited to those in the character set installed in the external plotter. A sample plot is shown in Fig. 10a, with the manually contoured version in Fig. 10b. Obviously the software described is only a small subset of what could be implemented depending upon the research need.

Report no. changed (Mar 2006): SM-183-UU

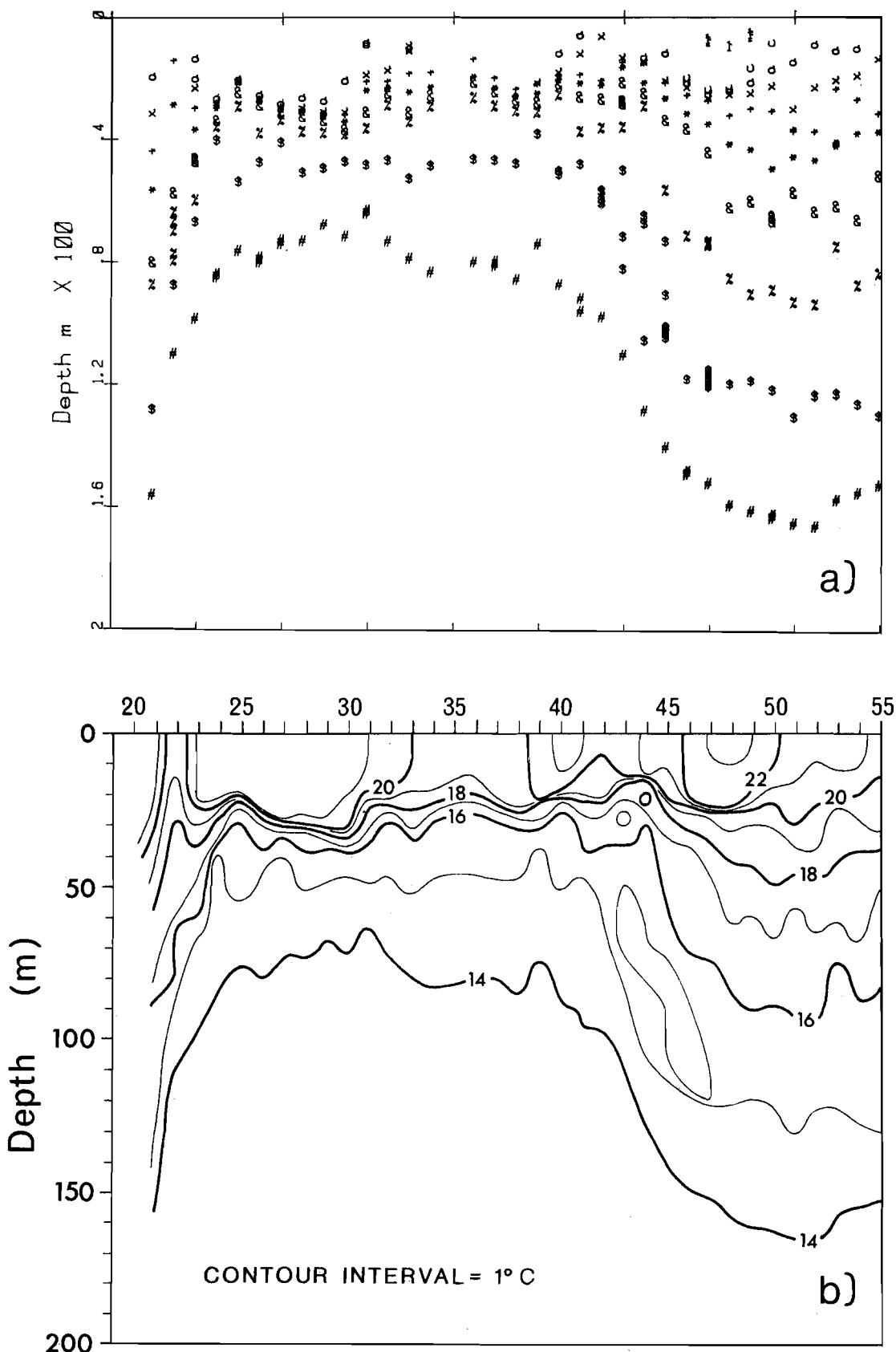

FIG. 10 SAMPLE PLOTS OF TEMPERATURE PROFILES
 a) Original plot with symbolic delineation of isotherms
 b) Manually contoured isotherms (from Fig. 10a).
 The scale at the top represents the numbering of the XBT's that were deployed at regular intervals.

Report no. changed (Mar 2006): SM-183-UU

SUMMARY

The SACLANTCEN-developed flexible XBT digital data acquisition and analysis system has been described. It is transportable, thus suitable for ships of opportunity as well as research vessels. As presently configured it is microcomputer-controlled but can be connected to any computer that will support the IEEE-488 General Purpose Interface Bus. It acquires the data from the probe with 12 bit precision at 10 Hz. The data can be automatically reduced to 20 or fewer temperature depth pairs and coded in standard format for radio messages. The same concept could be used as an interface for the AXBT and newer XSV. A discussion of other work on the XBT as an instrument is included and a bibliography of pertinent reports is given.

REFERENCES

The following reports have been retrieved from the computerised bibliography compiled by R.F.J. Winterburn and C. Pedenovi and have been programmed in the SACLANTCEN UNIVAC 1108 computer.

1. GEORGI, D., DEAN, J. and CHASE, J. XBT probe-to-probe thermistor temperature variability. Polymode News, 71, 1979: 1, 5-7.
2. MCDOWELL, S. A note on XBT accuracy. Polymode News, 29, 1977: 1,4.
3. MCDOWELL, S. and DORSON D. An XBT digitizer/cassette recording system. Polymode News, 50, 1978: 1, 4-5.
4. FEDOROV, K. N., GINSBURG, A.I. and ZATSEPIN, A.G. Systematic differences in isotherm depths derived from XBT and CTD data. Polymode News, 50, 1978: 1,6.
5. SEAVER, G. and KULESHOV, S. Experimental and analytical error of the expendable bathythermograph. Journal of Physical Oceanography, 12, 1982: 592-600.
6. ANDERSON, E.R. Expendable bathythermograph (XBT) accuracy studies. NOSC-TR-550. Naval Ocean Systems Center, San Diego, CA., 1980.
7. KRONER, S.M. and BLUMENTHAL, B.P. Guide to common shipboard expendable bathythermograph (SXBT) recording malfunctions NOORP-21. NSTL Station, Bay St. Louis, MS., 1978. Naval Oceanographic Office.
8. FISHER, A. and RILEY, L. An investigation of XBT encoding errors and their effect on sonar range computation. NAVOCEANO TR-234. Washington D.C., Naval Oceanographic Office, 1977.

Report no. changed (Mar 2006): SM-183-UU

9. GEHIN, C., MARTINELLI, G., MENELLI, and SPINA, F. The SACLANTCEN shipborne-computer environmental-data acquisition system, Vol. 4: On line data acquisition of XBT temperature profiles. SACLANTCEN SM-70, La Spezia, Italy, SACLANT ASW Research Centre, 1975. [AD A 012 378]
10. STEGEN, G.R., DELISI, D. P. and VON COLLN, R.C. A portable digital recording, expendable bathythermograph (XBT) system. Deep-Sea Research, 22, 1975: 447-453.
11. MESECAR, R. and WAGNER, J. An XBT digital recording and display system. In: INSTITUTE OF ELECTRICAL AND ELECTRONICS ENGINEERS and COUNCIL ON OCEANIC ENGINEERING and MARINE TECHNOLOGY SOCIETY. Oceans '79, fifth annual combined conference, September 17-19, 1979, San Diego, California. Piscataway, NJ, IEEE, 1979: pp. 598-601.
12. LANGE, R.E. and JOHNSON, B.P. Expendable bathythermographs as temperature microstructure profilers. Review of Scientific Instruments 53, 1982:59-64.
13. CALDWELL, D.R., WILCOX, S.D. and MATSLER, M. A freely falling probe for a small-scale temperature gradients. Limnology and Oceanography, 20, 1975:1034-1042.
14. WINTERBURN, R.F.J. and Wananmaker, B. A method for comparing digital XBT compression techniques, SACLANTCEN SM-131, La Spezia, Italy, SACLANT ASW Research Centre, 1979. [AD A 081 997]
15. INTERGOVERNMENTAL OCEANOGRAPHIC COMMISSION. Manual of International Oceanographic Data Exchange. IOC, Technical Series 3rd revised edition Paris, Unesco, 1973: p. 13.
16. WANNAMAKER, B. XBT measurements near the sea surface; considerations for satellite IR comparisons and data bases. SACLANTCEN SM-132, La Spezia, Italy, SACLANT ASW Research Centre, 1980.[AD A 086 485]
17. WOOD, W. Practical accuracy of sippican T- XBTs. Patricia Bay, Victoria B.C., Institute of Ocean Sciences, 1976.
18. FISHER, A. The ICAPS water mass history file, NOOR0-19, Bay St. Louis, Ms. Naval Oceanographic Office, 1978.
19. FLIERL, G.R. and ROBINSON, A.R. XBT measurements of thermal gradients in the Mode eddy. Journal of Physical Oceanography, 7, 1977:300-302.
20. EMERY, W.J. and DEWAR, J.S. Mean-temperature-salinity, salinity-depth and temperature depth curves for the North Atlantic and the North Pacific. Progress in Oceanography, 11, 1982:219-305.
21. WINTERBURN, R.F.J. The SACLANTCEN oceanographic data base, Vol.1: Design criteria and data structure and content. SACLANTCEN SM-150, La Spezia, Italy, SACLANT ASW Research Centre, 1980. [AD A 103 277]

Report no. changed (Mar 2006): SM-183-UU

KEYWORDS

BT
CONDUCTIVITY-TEMPERATURE-DEPTH PROFILE
CONTOUR PLOTTING
CTD
DENSITY
DIGITAL EXPENDABLE BATHYTHERMOGRAPH
DIGITAL XBT
EXPENDABLE BATHYTHERMOGRAPH
HORIZONTAL VARIABILITY
ISOTHERM FOLLOWING
MECHANICAL BATHYTHERMOGRAPH
MICROCOMPUTER
MINICOMPUTER
OCEANIC VARIABILITY
PROFILES
RELIABILITY
SALINITY-TEMPERATURE-DEPTH PROFILE
SIPPICAN Mk-9
SIPPICAN T5
SIPPICAN T7
SONAR PERFORMANCE
SOUND SPEED
STD
TEMPORAL VARIABILITY
THERMAL PROFILE
XBT

Report no. changed (Mar 2006): SM-183-UU

SACLANTCEN SM-183

INITIAL DISTRIBUTION

		Copies			Copies
<u>MINISTRIES OF DEFENCE</u>			<u>SCNR FOR SACLANTCEN</u>		
JSPHQ Belgium	2	SCNR Belgium	1		
DND Canada	10	SCNR Canada	1		
CHOD Denmark	8	SCNR Denmark	1		
MOD France	8	SCNR Germany	1		
MOD Germany	15	SCNR Greece	1		
MOD Greece	11	SCNR Italy	1		
MOD Italy	10	SCNR Netherlands	1		
MOD Netherlands	12	SCNR Norway	1		
CHOD Norway	10	SCNR Portugal	1		
MOD Portugal	2	SCNR Turkey	1		
MOD Spain	2	SCNR U.K.	1		
MOD Turkey	5	SCNR U.S.	2		
MOD U.K.	20	SECGEN Rep. SCNR	1		
SECDEF U.S.	65	NAMILCOM Rep. SCNR	1		
 <u>NATO AUTHORITIES</u>			 <u>NATIONAL LIAISON OFFICERS</u>		
Defence Planning Committee	3	NLO Canada	1		
NAMILCOM	2	NLO Denmark	1		
SACLANT	10	NLO Germany	1		
SACLANTREPEUR	1	NLO Italy	1		
CINCWESTLANT/COMOCEANLANT	1	NLO U.K.	1		
COMSTRIKFLTANT	1	NLO U.S.	1		
COMIBERLANT	1				
CINCEASTLANT	1				
COMSUBACLANT	1				
COMMAIREASTLANT	1	<u>NLR TO SACLANT</u>			
SACEUR	2	NLR Belgium	1		
CINCNORTH	1	NLR Canada	1		
CINC SOUTH	1	NLR Denmark	1		
COMNAVSOUTH	1	NLR Germany	1		
COMSTRIKFORSOUTH	1	NLR Greece	1		
COMEDCENT	1	NLR Italy	1		
COMMARAIARMED	1	NLR Netherlands	1		
CINCHAN	3	NLR Norway	1		
		NLR Portugal	1		
		NLR Turkey	1		
		NLR UK	1		
		NLR US	1		
		Total initial distribution	246		
		SACLANTCEN Library	10		
		Stock	24		
		Total number of copies	280		